

NITCHI

LEVER HOIST RB5



DURABILITY

The RB5 is manufactured with durable and robust construction the NITCHI products are renowned for. The durability and ruggedness will ensure long use with less maintenance and repair costs.

COMPACT AND LIGHTWEIGHT

The refined well-balanced, compact, lightweight design of RB5 is the result of high quality materials used together with the latest technology.

ENCLOSED DESIGN

The enclosed design of RB5 will provide higher protection against water, dirt and other foreign matter.

LOAD CHAIN

The super-tough heavy-duty galvanized load chains are exclusively heat-treated, special alloy steel.

HOOKS

The new large opening, deep pocketed hooks swivel in all directions and are made of high grade steel, drop forged and expertly heat-treated for extra strength.

LOAD CHAIN GUIDE

The super-tough forged steel load chain guides are longwearing, and will provide increased protection against jamming of the load chain and load sheave.

TWO INDEPENDENT PAWLS

(0.8t-6.3t)

Two alternately functioning independent pawls give double safety and make fine adjustments possible.

OVERLOAD PROTECTION

(Optional equipment)

Overload Protection is recommended for additional safety to personnel and materials. When the setting is exceeded, the Precision Clutch Type Overload Protection will instantly prevent hoisting.

SINGLE-HANDED FREE-WHEELING

The length of the load chain can be quickly adjusted with one hand by merely switching the Change-over lever to "NEUTRAL (Free-wheeling)"



NITCHI MODEL RB5 LEVER HOIST

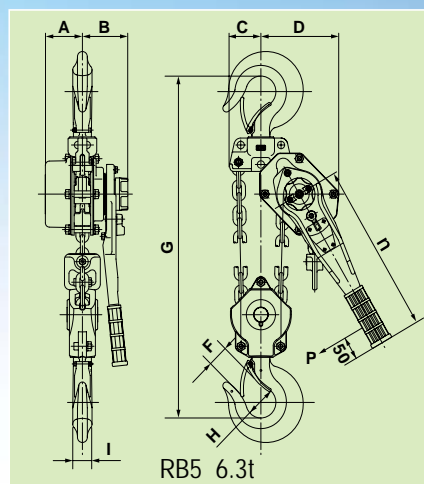
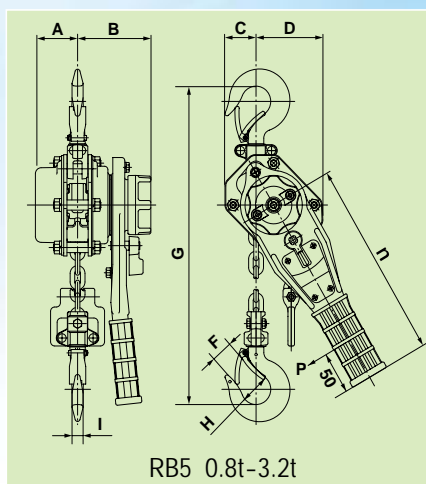
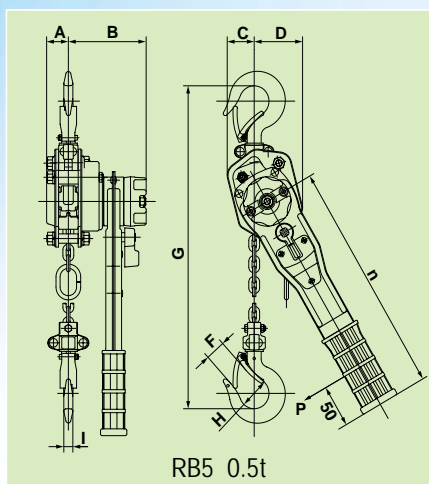

STANDARD SPECIFICATIONS

Item No.	Rated load (t)	Lift (m)	Test load (t)	Load chain		Minimum head room G (mm)	Pulling efforts P(N)	Net weight (kg)	Major dimensions (mm)							
				Type	Falls				A	B	C	D	F	H	I	n
RB50050(F)	0.5	1.5	0.75	T-4	1	280	416	3.5	27	95	33	59	24	36	11	275
RB50080(F)	0.8		1.2	T-5.6	1	290	260	5.5	52	90	38	82	24	36	13.5	235
RB50160(F)	1.6		2.4	V-7.1	1	330	305	9.6	65	98	41	97	31	45	20	370
RB50320(F)	3.2		4.8	V-9	1	430	385	16.3	83	102	53	124	35	52	24	370
RB50630(F)	6.3		7.9	V-9	2	580	390	30.5	83	102	70	174	46	67	43	370

N.B. 1. The (F) in the Item Numbers are for Lever Hoists with Overload Protection.

2. When compared to the above photographs, the Chain ends (Stop grips) of the actual products will face a different direction.

The design, materials and specifications are subject to change for improvements without notice.



NO. 7-17, 4-CHOME, YOSHITA,
HIGASHI-OSAKA, OSAKA 578-0924, JAPAN
<http://www.nich.co.jp/>