

Instruction Manual and Safety Instructions for Owners (Operators)

Chain lever hoist Elephant lever model YA/YAⅢ

(Automatic free chaining type)

**Capacity: 0.8t to 9t
(1,763 to 19,841lbs)**

Model No. : _____

Serial Number : _____

Date of initial use : _____

※The above information needs to be filled in by the purchaser.

Warning

Owners (operators) are required to completely understand the installation, operation, maintenance and inspection of the equipment described within this instruction manual prior to use. Failure to understand or comply with the contents of this Manual may result in property damage, serious injury or death.

- Thank you very much for your purchase of Elephant products.
- Before using Elephant lever hoists, please read this instruction manual carefully to ensure that you fully understand the product and its proper use.
- Please store this instruction manual securely as it is required for maintenance, inspection, disassembly and assembly of the product.



ELEPHANT CHAIN BLOCK CO.,LTD.

Index



1. Safety Information and Warnings	2
1.1 Terminology	2
1.2 Restrictions on the use of this Equipment are as follows :	3
1.3 Warning Tags, Labels	4
2.Regarding the personnel operating and using lever hoists	5
2.1 Names of Parts	5
2.2 Unpacking the Product	5
2.3 Specifications Table	5
2.3.1 YA Dimensions	6
2.3.2 YA Hook Dimensions	7
2.4 YAⅢ (with Overload Protection)	7
2.5 YAS Shipyard Hook	8
2.5.1 YAS Hook Dimensions	8
2.6 YAR Latch Lock Hook	9
2.6.1 YAR Hook Dimensions	9
3.Pre-Operational Procedures	10
3.1 Chain	10
3.2 Lever Hoist Installation	11
3.3 Pre-Operational Inspection and Test Run	11
4.Precautions for Use	12
4.1 General Handling	12
4.2 Precautions before Operation	13
5.Lever Hoist Operation	17
5.1 Regarding automatic free chaining operation	17
5.2 Adjustment of Load Chain Length (Free chaining Operation)	17
5.3 Lifting/Lowering Operation	18
5.4 Overload Protection (Model YAⅢ)	19
6. Inspection of lever hoists	20
6.1 Definition	20
6.2 General	20
6.3 Inspection Category	20
6.4 Pre-use inspections	21
6.5 Normal inspection	21
6.6 Routine Inspection	21
6.7 Load Chain Inspection	22
6.8 Operational Tests	22
6.9 Load Tests	22
6.10 Inspection, Testing Methods and Reference Values	23
7. Disassembly and Assembly Adjustment	39
7.1 Tools and Equipment/Consumables used for Disassembly/Assembly	39
7.2 Disassembly of Model YA	41
7.3 Assembly and Adjustment	44
7.4 Is this a malfunction!? First check for (commonly found assembly errors)	56
Inspection records	60
Breakdown Schematics	62
Warranty	65

1. Safety Information and Warnings

1.1 Terminology

This Instruction Manual contains safety information necessary for owners responsible for the installation, operation, maintenance and inspection of this Product, and for operators actually engaged in the operation of the Product. In order to fully comprehend the structure and operation of this Product, please make sure that you understand the contents of this Instruction Manual.

The safety information provided within this Instruction Manual includes circumstances possibly leading to hazardous situations. The four terms "Danger, Warning, Caution, and Notice" are used to clearly indicate the seriousness of hazardous conditions.

 DANGER	Danger indicates an imminently hazardous situation which, if not avoided, may result in fatalities or serious injuries.
 WARNING	Warning indicates a potentially hazardous situation which, if not avoided, may result in fatalities or serious injuries.
 CAUTION	Caution indicates a potentially hazardous situation which, if not avoided, may result in minor or moderate injuries.
NOTICE	Notices cover implementation procedures which do not require caution against personal injury.

DANGER

- Never perform any operation that could result in a [DANGER] condition as described in the Instruction Manual.

WARNING

- Failure to comprehend and comply with the restrictions described within this Instruction Manual may result in fatalities, severe injuries, or property damage.
- Owners and operators of this Equipment are prohibited from using the Equipment for any purpose other than that for which it was originally intended, or make any modifications that may impair the safety of this Equipment.
- This Equipment must not be used in a corrosive atmosphere such as acidic, alkaline, steam, high temperature, toxic gas, salt water, etc.
- This Equipment must not be used in a condition where it is repeatedly subjected to dynamic loads due to connecting it to other powered cranes or such load application devices.
- This Equipment shall not be used for transporting, supporting, lifting, or lowering people, or for transporting, supporting, lifting, or lowering loads above people. This Equipment is not intended for transporting people in any way.

CAUTION

- Owners and operators of this Equipment are required to record the model, serial number, and initial date of use on the front cover of this Manual prior to using the Equipment.
- This Manual is intended to provide safety information on installation, operation, maintenance, and inspection of the Equipment under normal operating conditions.
- If this Equipment is used in combination with other equipment, the supplier of the equipment combination concerned is responsible for ensuring compliance with applicable industrial standards, federal, state, and local laws and regulations.
- Repair and maintenance of this Equipment shall be conducted only with parts certified by ELEPHANT CHAIN BLOCK CO., LTD.

NOTICE

- Owners and operators of this Equipment are responsible for ensuring that all personnel engaged in the installation, operation, inspection, test, and servicing of this Equipment sufficiently comprehend the contents of this Manual, the applicable portions of ANSI/ASME B30.21 "Lever Hoists" standards, and OSHA regulations.
- Owners and operators are responsible for the installation, operation, inspection, testing, and maintenance of this Equipment in accordance with the provisions of the ANSI/ASME B 30.21 "Lever Hoists" standards and applicable OSHA regulations.
- Owners and operators should contact the dealer of this Equipment if any item in this Manual is unclear, or in case any additional information is necessary. Do not install, operate, inspect, test, or maintain this Equipment unless all uncertain articles are clarified accordingly.
- Designate a periodic inspection schedule for this Equipment in accordance with the requirements of ANSI/ASME B30.21 "Lever Hoists," maintaining records of the inspections conducted.

1.2 Restrictions on the use of this Equipment are as follows :

- (1) This Equipment is to be used to pull or lift loads in horizontal or diagonal directions, or to tighten loads.
- (2) Do not use this Equipment to transport humans.
- (3) Do not incorporate the Product as part of facility equipment or machinery.
- (4) The Equipment is to be used within a temperature range of -40°C to $+60^{\circ}\text{C}$ (with humidity of 100%RH or less).
- (5) Never use this Equipment in locations constantly subjected to wind, rain, or waves, or in locations susceptible to salt damage, acid, alkali, etc., as this may cause damage to the Equipment and load chains.

1.3 Warning Tags, Labels

The warning tag indicated in Figure 1 below is attached to this Equipment upon shipment from the factory. Owners and operators of this Equipment are required to comprehend and comply with all articles provided on warning tags and labels.

If tags are not attached on the no-load side of the load chain of the Equipment, procure tags from your dealer and attach them accordingly. Read and follow all warnings attached to this Equipment. (Tag is not shown actual size.)

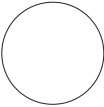

! WARNING

- Indicates hazardous situations that, if not avoided, may result in fatalities, serious injuries, or property damage.
- To avoid hazardous situations, perform the following actions:

- (1) Read this Instruction Manual thoroughly and understand its contents.
- (2) Do not operate the Equipment controls except by hand (do not use any tools or objects).
- (3) Never hang objects exceeding the rated load.
- (4) Never operate the Equipment by means of pipes, etc. inserted into the Equipment or by stepping on the Equipment with your feet.
- (5) When hanging objects on the hook, be sure to hang in the correct position at the center of the hook. Do not use the Equipment if the load cannot be hung in the correct position.
- (6) Do not remove caution labels or nameplates from the unit or use the unit with caution labels or nameplates that are illegible.
- (7) Never use load chains that are twisted, tangled, cracked, that have abnormal meshing, or that are elongated or worn beyond the specified limits.
- (8) Do not use this Equipment if it is damaged or emits abnormal noises.
- (9) Do not use this Equipment as a slinging tool.
- (10) Do not apply lateral-wise loads to the neck portion of the hook.
- (11) Do not use this Equipment to support, lift, or transport people.
- (12) Never suspend a load with the tip of the hook.
- (13) Never use Equipment with deformation or damage on either the top or bottom hooks.
- (14) Never use Equipment with the latch for the hook detached or damaged.
- (15) Do not modify this Equipment in any way.

ELEPHANT CHAIN BLOCK CO., LTD.

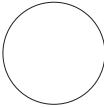

! ADVERTENCIA

- Indica situaciones peligrosas que, si no se evitan, pueden provocar muertes, lesiones graves o daños materiales.
- Para evitar situaciones peligrosas, tome las siguientes medidas :

- (1) Lea detenidamente este Manual de instrucciones y asegúrese de que entiende su contenido.
- (2) No accione los mandos del equipo si no es con la mano (no utilice ninguna herramienta u objeto).
- (3) No cuelgue nunca objetos por encima de la carga nominal.
- (4) Para manejar el equipo, no introduzca nunca tubos, etc., ni pise el equipo con los pies.
- (5) Cuando cuelgue objetos en el gancho, asegúrese de hacerlo en la posición correcta en el centro del gancho. No utilice el equipo si no puede colgarse la carga en la posición correcta.
- (6) No retire las etiquetas de precaución ni las placas de identificación de la unidad, ni utilice la unidad si las etiquetas de precaución o las placas de identificación son ilegibles.
- (7) No utilice nunca cadenas de carga que estén torcidas, enredadas, agrietadas, que tengan un engranaje anormal o que se hayan alargado o desgastado más allá de los límites especificados.
- (8) No utilice este equipo si está dañado o emite ruidos anormales.
- (9) No utilice este equipo como una herramienta de lanzamiento.
- (10) No aplique cargas laterales en la parte del cuello del gancho.
- (11) No utilice este equipo para sostener, levantar ni transportar personas.
- (12) No suspenda nunca una carga con la punta del gancho.
- (13) No utilice nunca el equipo si hay deformaciones o daños en los ganchos superior o inferior.
- (14) No utilice nunca el equipo si el cierre del gancho está suelto o dañado.
- (15) No modifique este equipo de ningún modo.

ELEPHANT CHAIN BLOCK CO., LTD.

Figure 1

2. Regarding the personnel operating and using lever

2.1 Names of Parts

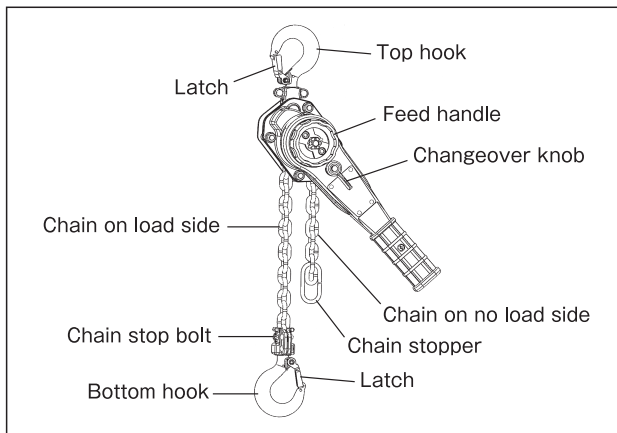

Figure 2

2.2 Unpacking the Product

- (1) Check that the box labeling and product matches your order.
- (2) Please confirm the contents of the container.
- (3) Make sure the product has not been damaged during transportation.
- (4) Check that no accessories are missing or disengaged.
- (5) Check the integrity and condition of screws, fittings, etc. for all components.

2.3 Specifications Table

Table 1 Specifications

Model	Rated load	Lift	Load chain		Minimum head room	Hand force	Self-weight
			Diameter	Number of chain falls			
Y A-80	0.8t	5ft	5.6mm	1	290mm	294N	6.0kg
	1,763lbs		0.22in		11.41in	30kgf	13.22lbs
Y A-100	1t	5ft	5.6mm	1	312mm	363N	6.2kg
	2,204lbs		0.22in		12.28in	37kgf	13.66lbs
Y A-160	1.6t	5ft	7.1mm	1	352mm	353N	9.2kg
	3,527lbs		0.27in		13.85in	36kgf	20.28lbs
Y A-320	3.2t	5ft	9mm	1	420mm	432N	15.5kg
	7,054lbs		0.35in		16.53in	44kgf	34.17lbs
Y A-630	6.3t	5ft	9mm	2	564mm	441N	26.5kg
	13,889lbs		0.35in		22.20in	45kgf	58.42lbs
Y A-900	9t	5ft	9mm	3	689mm	451N	42.0kg
	19,841lbs		0.35in		27.12in	46kgf	92.59lbs

Minimum head room and lift

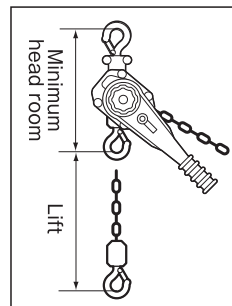

2.3.1 YA Dimensions

YA-80
YA-100
YA-160
YA-320

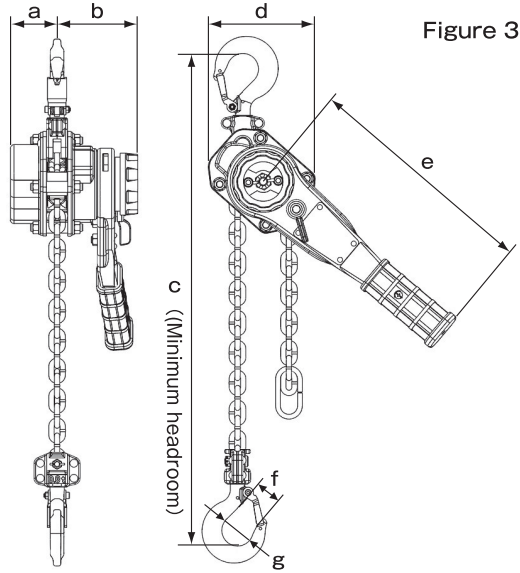
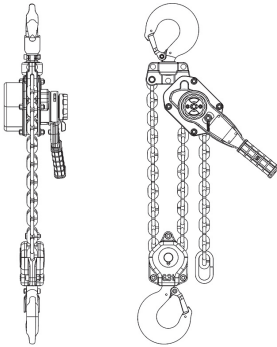

Figure 3

YA-630



YA-900

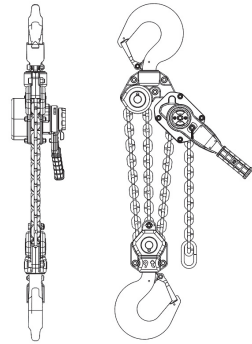

Table 2

Model	Rated load (t)	a	b	c	d	e	f	g
YA-80	0.8t	53mm	91mm	290mm	122mm	268mm	23mm	36mm
	1,763lbs	2.08in	3.58in	11.41in	4.80in	10.55in	0.90in	1.41in
YA-100	1t	53mm	91mm	312mm	122mm	268mm	28mm	43mm
	2,204lbs	2.08in	3.58in	12.28in	4.80in	10.55in	1.10in	1.69in
YA-160	1.6t	63mm	99mm	352mm	136mm	310mm	29mm	43mm
	3,527lbs	2.48in	3.89in	13.85in	5.35in	12.20in	1.14in	1.69in
YA-320	3.2t	82.5mm	104mm	420mm	180mm	360mm	36mm	53mm
	7,054lbs	3.24in	4.09in	16.53in	7.08in	14.17in	1.41in	2.08in
YA-630	6.3t	82.5mm	104mm	564mm	235mm	360mm	47mm	70mm
	13,889lbs	3.24in	4.09in	22.20in	9.25in	14.17in	1.85in	2.75in
YA-900	9t	82.5mm	104mm	689mm	300mm	360mm	73mm	85mm
	19,841lbs	3.24in	4.09in	27.12in	11.81in	14.17in	2.87in	3.34in

2.3.2 YA Hook Dimensions

- (1) Measure dimensions A, B, and C in Figure 4 below, and record the actual measurements at the time of purchase. Although limit dimensions may also be determined based on the reference standard values, it should be noted that there will be some dimensional errors due to the forging process.
- (2) If any of dimensions A, B, and C have reached the indicated limits, replace the hook with a new one.
- (3) The opening of the hook will expand in the event loads exceeding the rated load are applied to the mouth, or if a concentrated load is applied to the tip section.
- (4) Hooks with expanded openings lose their original strength and shock-absorbing capabilities, and should be replaced upon exceeding the limit.
- (5) Never reuse hooks with expanded openings straightened by heating or repairing. Such attempts could cause extremely hazardous results. Hooks with flaws 1 mm or more deep or bent/twisted hooks should also be replaced.

Table 3

Model	Capacity	A	B	C
YA-80	0.8t	46.6mm	19mm	15mm
	1,763lbs	0.86in	0.59in	0.74in
YA-100	1t	51mm	22mm	16mm
	2,204lbs	1.02in	0.62in	0.86in
YA-160	1.6t	55mm	26mm	21mm
	3,527lbs	1.18in	0.82in	1.02in
YA-320	3.2t	67mm	35mm	28mm
	7,054lbs	1.61in	1.10in	1.37in
YA-630	6.3t	91.5mm	46mm	34mm
	13,889lbs	2.16in	1.33in	1.81in
YA-900	9t	125mm	61.1mm	47.5mm
	19,841lbs	3.01in	1.87in	2.40in

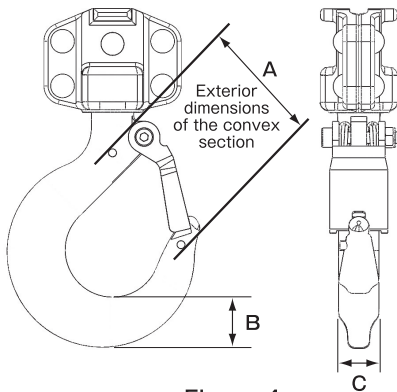

Figure 4

※Dimensions of the top and bottom hooks are the same.

Purchased Product			
Model	A	B	C

※Record actual measurement value at the time of purchase.

2.4 YAⅢ (with Overload Protection)

- ※The “Ⅲ” in model YAⅢ indicates overload protection.
- ※Except for the presence of dedicated parts, model YAⅢ does not differ from model YA. (See breakdown schematics)
- ※Overload protection means that when attempting to hoist a load in excess of the rated load, the lever will idle away (slip) preventing the load from being lifted. (The overload setting cannot be altered.)

2.5 YAS Shipyard Hook

The "S" in model YAS indicates the attachment of a shipyard hook.
 The "Shipyard hook" is a special hook to facilitate canning and butting operations within the shipbuilding industry.
 The shipyard hook has a reinforced tip, as compared to a normal hook.

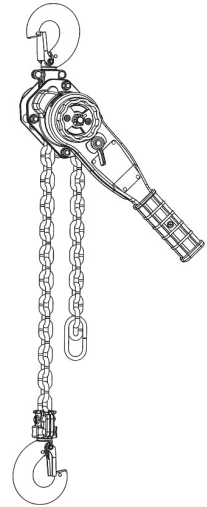

⚠ WARNING

- (1) Read this Instruction Manual thoroughly and understand its contents.
- (2) Do not apply lateral-wise load to the neck portion of the hook.
- (3) Make sure canning hooks are securely fixed to the load and will not dislodge from the load.

2.5.1 YAS Hook Dimensions

Table 4

Model	Rated load	A	B	C
YAS-80	0.8t	54.0mm	23.5mm	19.0mm
	1,763lbs	2.12in	0.92in	0.74in
YAS-100	1t	54.0mm	23.5mm	19.0mm
	2,204lbs	2.12in	0.92in	0.74in
YAS-160	1.6t	55.0mm	28.5mm	23.0mm
	3,527lbs	2.16in	1.12in	0.90in
YAS-320	3.2t	70.2mm	37.0mm	28.0mm
	7,054lbs	2.76in	1.45in	1.10in

※Dimensions of the top and bottom hooks are the same.

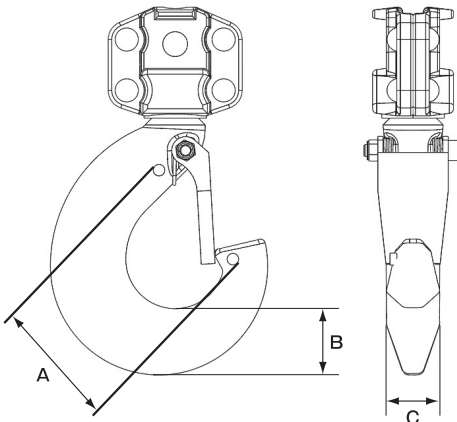

Figure 5

Purchased Product			
Model	A	B	C

※Record actual measurement value at the time of purchase.

2.6 YAR · Latch Lock Hook

※The "R" in model YAR indicates a latch lock hooks.

Latch lock hooks are outward-opening, allowing easy removal of slinging tools.

The hook will not open when under load.

The hook will not open unless the operator unlocks it even when no load is applied.

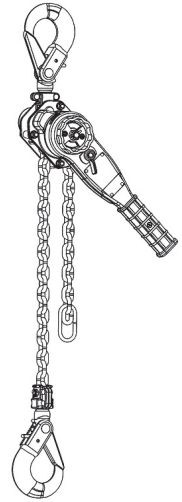

WARNING

- (1) Read this Instruction Manual thoroughly and understand its contents.
- (2) Do not apply lateral-wise load to the neck portion of the hook.
- (3) Make sure the latch lock hooks are securely fixed to the load and will not dislodge from the load.

2.6.1 YAR Hook Dimensions

Table 5

Model	Rated load	A	B	C
YAR-80	0.8t	29.5mm	19.5mm	14.0mm
	1,763lbs	1.16in	0.76in	0.55in
YAR-100	1t	29.5mm	19.5mm	14.0mm
	2,204lbs	1.16in	0.76in	0.55in
YAR-160	1.6t	47mm	28.5mm	24.0mm
	3,527lbs	1.85in	1.12in	0.94in
YAR-320	3.2t	52mm	39.0mm	28.0mm
	7,054lbs	2.04in	1.53in	1.10in

※Dimensions of the top and bottom hooks are the same.

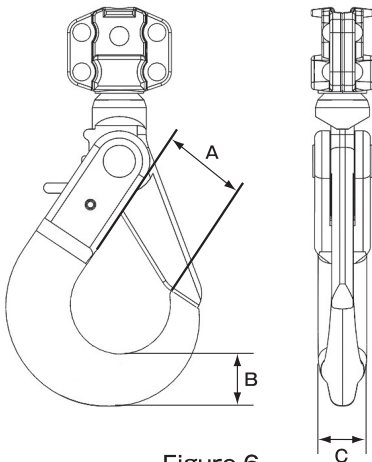

Figure 6

Purchased Product			
Model	A	B	C

※Record actual measurement value at the time of purchase.

3. Pre-Operational Procedures

3.1 Chain

WARNING

- (1) Make sure the chain stopper is attached to the second-to-last chain link on the no-load side of the load chain.
- (2) Before operating the equipment, make sure the load chain is not twisted or tangled. Hook for 6.3t (2 falls) and 9t (3 falls) are multiple falls hook. Make sure the hooks are not reversed. Be sure to correct any problems before using this equipment. (Figure 7, Figure 8)

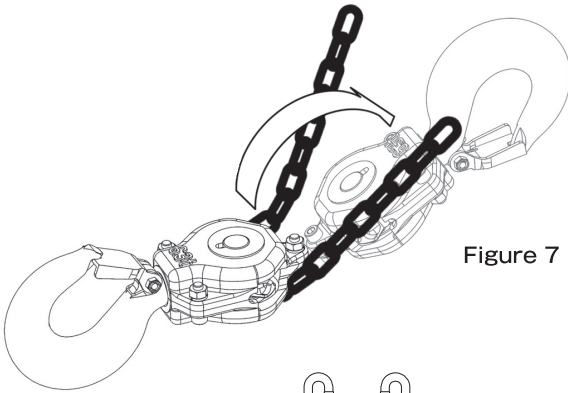

Figure 7

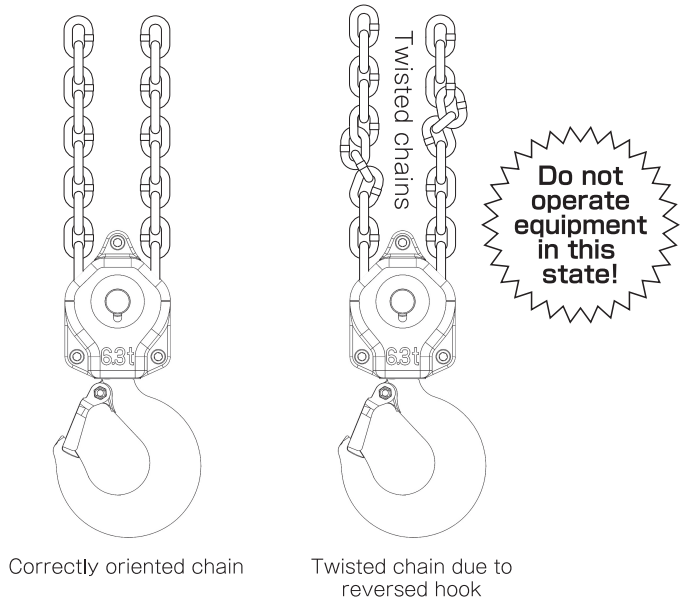

Figure 8

3.2 Lever Hoist Installation

WARNING

- (1) Never install lever hoists without sufficient expertise in the equipment.
- (2) Make sure the location of equipment installation has sufficient strength to support the equipment under load.
- (3) When suspending a load from the hook, be sure to hang it in the correct position at the center of the hook.
- (4) Never suspend loads from the tip of a hook.
- (5) Never use the hoist with the hook working as a fulcrum (the suspended hook is shifted from its vertical position).

CAUTION

※Do not attach hooks in the manner illustrated in the figure below (both up and down) as it is dangerous.



Correct usage
Suspend from the
axis of the hook.



Suspended objects or
slings are not hung in the
proper position.



The latch is not
functioning
properly.



The tip of the hook is not
capable of fully supporting
the load.

Figure 9

NOTICE

- (1) When installing the hoist outdoors, lubricate the load chain. After use, clean the lever, apply lubricant, and store in a dry place.

3.3 Pre-Operational Inspection and Test Run

WARNING

- (1) Before use, check the chain sling, wire rope, sling and all other hoisting equipment for appropriate rated load. Inspect all equipment for damage, replace it as needed with new equipment, or have it repaired before use.
- (2) Before operating this equipment, check the entire length of the chain and straighten any twists.
- (3) Measure the dimensions of the top and bottom hooks at the time of purchase, and record the actual measurements.
- (4) Make sure the model, serial number, and initial date of use for this equipment is recorded accordingly at the time of purchase.
- (5) Make sure the location of equipment installation has sufficient strength to support the equipment under load

3.3 Pre-Operational Inspection and Test Run (continued)

WARNING

- (6) Make sure the equipment has been installed correctly.
- (7) Make sure all nuts, bolts, and cotter pin are sufficiently secured in position.
- (8) Understand the work to be done with the equipment and operate accordingly.
- (9) Users are required to ensure this equipment has been safely installed and operated in accordance with the applicable provisions of ANSI/ASME B30.21 "Lever Hoists" standard and OSHA regulations, and that the maintenance and inspection requirements have been met.
- (10) Before operating this equipment, make sure no interfering objects are present within its entire range of operation.

4. Precautions for Use

4.1 General Handling

DANGER

- (1) Individuals unfamiliar with the contents of the instruction manual and caution nameplate must not operate this product.
- (2) Do not use this product to support, lift, or transport people.
- (3) Do not allow anyone to enter the area underneath or within the movement range of suspended loads. Additionally, do not move the load above anyone. (Figure 10)
- (4) Use this product within a temperature range of -40°C to $+60^{\circ}\text{C}$ (with humidity of less than 100%RH).
- (5) Do not use this product in water.
- (6) Never use this equipment in locations constantly subjected to wind, rain, or waves, or in locations susceptible to salt damage, acid, alkali, etc., as this could cause damage to the equipment and load chains.

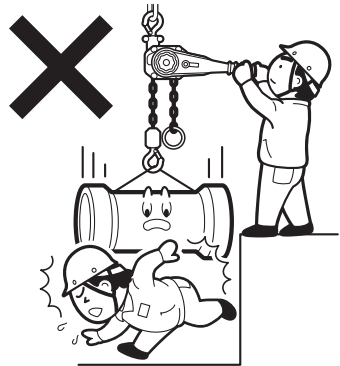

Figure 10

WARNING

- (1) Only operators who have thoroughly read and fully understand the contents of this instruction manual should carry out work related to inspection and repair of the equipment. It is also necessary to understand the ANSI / ASME B30.21 and ANSI / ASME B30.10 and related standards of ANSI / ASME. Use of this product without thorough understanding of all relevant information is strictly prohibited.
- (2) Those without an accurate understanding of its controls are not to operate this equipment.
- (3) Those without an understanding of the proper operating procedures for attaching loads to the top and bottom hooks are not to use this equipment.

WARNING

- (4) Operators are required to understand the adjustment, failure, and repair of this equipment. Operators unable to stop operation and take corrective action in the event of a malfunction are not to use this equipment.
- (5) Operators should be attentive of potential malfunctions of the equipment which may require adjustment or repair, and must stop operation and contact a supervisor immediately in the event such a malfunction occurs.
- (6) Individuals with restrictions in eyesight, field of vision, reaction time, or manual dexterity are not to operate this equipment.
- (7) Individuals without sufficient bodily control, those with physical deficiencies, are emotionally unstable, have a history of seizures, are prone to seizures, or are otherwise likely to operate the equipment in a manner potentially hazardous to the operator or others are not to operate this equipment.
- (8) Operator under the influence of drugs, medical drugs, or alcohol are not to operate this equipment.

NOTICE

Understanding of the hazard tags/labels and nameplate (tonnage) attached to the unit is required.

※From the provisions of the ANSI/ASME B30 standard:

- Engineering functions of this equipment alone cannot mitigate all hazards, which include hazards that can be mitigated by the operator's knowledge, experience, caution, and common sense. In order to enhance awareness of the above, fully understand the contents of this instruction manual and use the equipment safely.

4.2 Precautions before Operation

WARNING

- (1) Never suspend loads exceeding the rated load. (Figure 11)
- (2) Do not use this equipment if it is damaged or emits abnormal noises.
- (3) Never use load chains that are twisted, tangled, cracked, have abnormal meshing, or are elongated or worn beyond specified limits.
- (4) If attached with two or more load chains, do not use this equipment if the bottom hook is in an abnormal state of passing through the load chains. (Figure 12)
- (5) Do not intrude into the area beneath the load or within the moving range of the load. Additionally, do not move the load above anyone.
- (6) Never operate the hoist in such a manner as to let the load drop even a slight distance.
- (7) Never cut, splice, or weld the load chain.
- (8) Do not operate the lever hoist if the load cannot be suspended from the center portion of the hook.

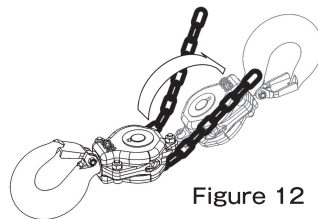
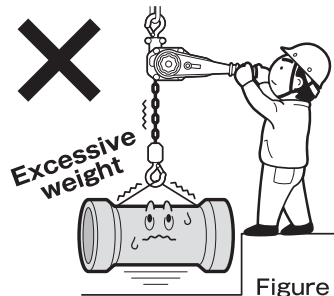

4.2 Precautions before Operation (continued)

WARNING

- (9) Do not use this equipment as a sling suspension device. Also, do not use with the load chain wrapped around the load.
- (10) Never operate equipment by means of pipes, etc. inserted into the Equipment or by stepping on the Equipment with your feet. (Figure 13)
- (11) Never apply loads exceeding the rated load on a single unit of this equipment when performing two-hoist lifting. (Figure 14)
- (12) Never over-wind or over-lower loads.
- (13) Never suspend a load with the tip portion of the hook. (Figure 15)
- (14) When suspending loads from the hook, never operate the hook in such a way that a lateral load is applied to either the top or bottom hooks.
- (15) Do not leave the load suspended for a long time.
- (16) Do not connect the grounding from welding machines to the load chain. (Figure 16)
- (17) Never allow welding electrodes to come in contact with the load chain.
- (18) Do not remove caution labels or nameplates from the unit or use the unit with caution labels or nameplates in an illegible condition.
- (19) Do not use the product if the nameplate affixed to the main unit is illegible.
- (20) Make sure that all personnel are clear of the support load.
- (21) Do not allow sparks from welding, etc. into come in contact with this equipment.
- (22) When lifting or moving a load, notify surrounding workers.
- (23) Never install this equipment without sufficient expertise in the equipment.
- (24) Make sure the location of equipment installation maintains sufficient strength to support the equipment under load.

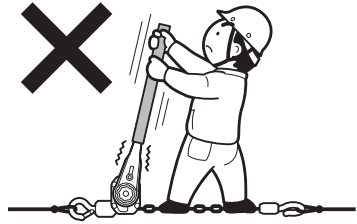

Figure 13

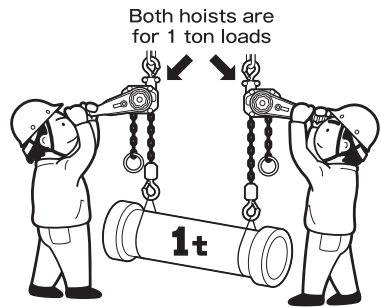

Figure 14

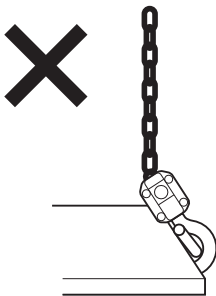

Figure 15

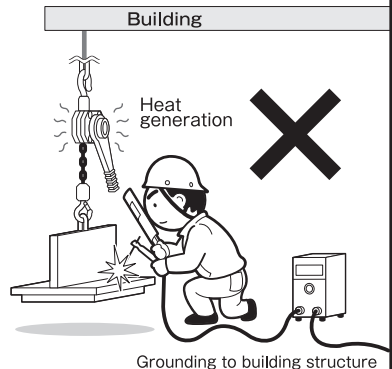

Figure 16

4.2 Precautions before Operation (continued)

WARNING

- (25) Do not allow anyone to ride on suspended loads. Never use the lever hoist for human transport purposes. (Figure 17)
- (26) Never reverse a suspended load without sufficient expertise in doing so.
- (27) Do not suspend excessive loads.
- (28) When maintaining the load in a suspended condition for a short period of time, be sure to leave the switch pawls in the lifting position.
- (29) Never use the hoist or the hook to work as a fulcrum.
- (30) Do not use damaged or deformed top/bottom hooks.
- (31) Never use this equipment if the load chain is deformed or damaged.
- (32) Do not operate the equipment with the load chain lodged against a steel plate or other corners. (Figure 18)
- (33) Do not operate the load chain by any means other than human power (do not use any tools or objects on the controls).
- (34) Do not apply abrupt force to the load chain during idle operation.
- (35) Suspend slings properly onto the hook.
- (36) During lifting, temporarily pause winding once either the load chain or sling comes under tension.
- (37) Keep the lever hoist unit and load chain clean and free of sand and other debris.
- (38) Make sure the lifting height is sufficient for the intended work.
- (39) Make sure the load chain is sufficiently lubricated.
- (40) Do not modify this equipment in any way.
- (41) Do not use with the load chain wrapped around the load. (Figure 19)
- (42) Do not suspend the load chain directly from rope hook fixtures on trucks. Do not use the load chain as a suspension device. (Figure 20)

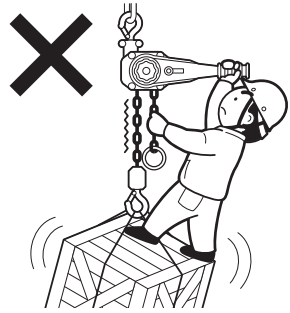

Figure 17

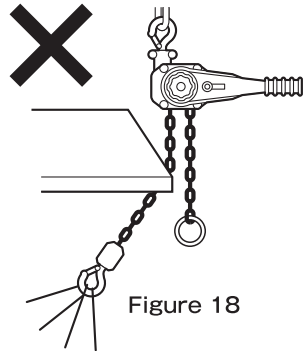

Figure 18

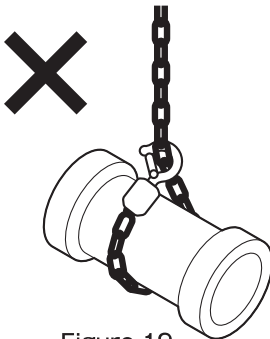

Figure 19

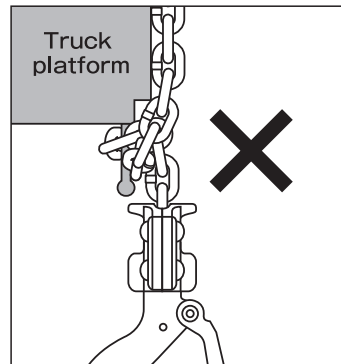

Figure 20

4.2 Precautions before Operation (continued)

WARNING

(43) Do not hang hooks onto the rope hook fixtures of trucks in a manner subjecting the neck portion of hooks to strain when tying down the cargo (could result in neck breakage).

(Do not use hooks in a manner that it is subjected to lateral bending forces.) (Figure 21)

Instead, hook wire slings onto the rope hook fixtures first, and then tie down the cargo.

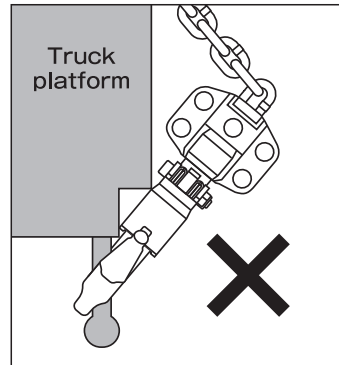

Figure 21

CAUTION

- (1) When operating this equipment, be sure to maintain a firm foothold, and otherwise ensure safe working conditions (for performance of operations).
- (2) Always check the brake function before using this equipment.
- (3) Make sure the latch for the hook is properly attached. The latch helps prevent slings, chain slings, and other slinging tools and loads from being released.
- (4) Make sure all obstacles are removed from the vicinity of the load.
- (5) Avoid shaking either the load or the hook.
- (6) Make sure the hook is moving in the predetermined direction.
- (7) Inspect this equipment periodically and replace any damaged or worn parts. Maintain records of the inspections.
- (8) Never use other than genuine parts from the manufacturer of this equipment.
- (9) When measuring applied loads, do not use the overload protection device as the measuring instrument.
- (10) Do not become distracted from the load during operation.
- (11) Repairs of the equipment must only be done by qualified service technicians.
- (12) After finishing operation of the hoist, wipe off any mud, water, and foreign matter, and apply lubrication to the chain and hook.
- (13) Never apply lubricants to the brake parts.
- (14) Store the equipment in a dry location, protected from rain and dew.
- (15) Always loosen the brake for storage, and never store the equipment with the brake in a tightened condition.
 - ※ If the hoist is stored with the brake tightened, it will not be able to perform lowering operations the next time it is used.
In this case, perform a lowering operation once to disengage the brake.
- (16) When disposing of this equipment, disassemble it to prevent its reuse by others.

5. Lever Hoist Operation

5.1 Regarding automatic free chaining operation

Model YA lever hoists are equipped with an "automatic free chaining operation system" enabling free chaining operation by simply switching the changeover knob in the absence of loads.

※Automatic free chaining operation enables the load chain to move freely by releasing the brake when there is no load.

5.2 Adjustment of Load Chain Length (Free chaining Operation)

DANGER

- (1) Never select the free chaining operation when a load is applied to the equipment. Always select it when there is no load.
- (2) Do not touch the feed handle when lifting or lowering loads.

WARNING

- (1) Be sure to check that the changeover knob is set to the correct position.

To adjust the length of the load chain in the absence of loads, perform the free chaining operation in the order shown in Figures 22 to 24 below:

- (1) Set the changeover knob to "N". The changeover knob is located beneath the feed handle.
- (2) Turn the feed handle leftward (counterclockwise) about 1/2 rotation.
- (3) Slowly pull the load chain on the no-load side (chain stopper side), then slowly pull the load chain on the load side (bottom hook side) to adjust the position according to the work to be performed.

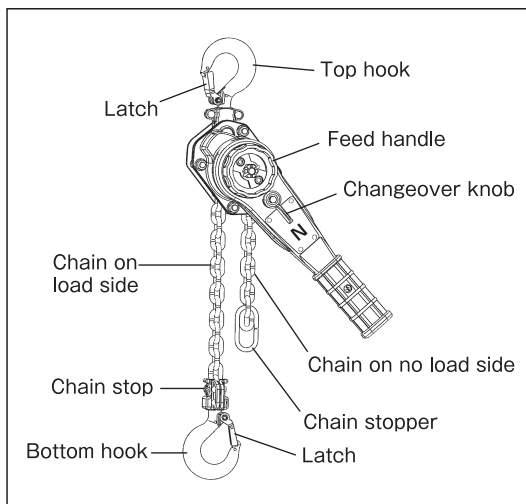

Free chaining method

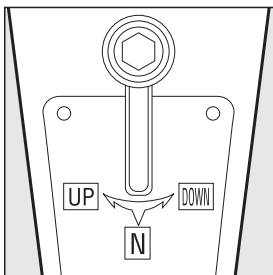

- (1) Set changeover knob to position "N".

Figure 22

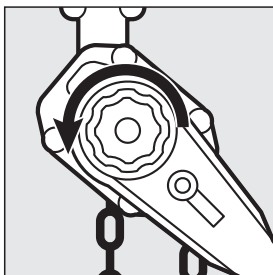

- (2) Turn feed handle leftward (counter clockwise) about 1/2 rotation.

Figure 23

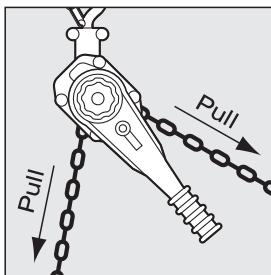

- (3) Slowly pull load chain on the no-load side (chain stopper side), then slowly pull load chain on the load side (bottom hook side), adjusting the position according to the work to be performed.

Figure 24

CAUTION

- (1) Do not abruptly pull on the load chain during free chaining operation.
- (2) Pulling with excessive force causes the brake to engage, rendering the load chain immobile. In such situations, readjustment is required.

5.3 Lifting/Lowering Operation

- (1) Set the hoist and adjust the load chain using free chaining operation to a height allowing for easy suspension of the load on the bottom hook.
- (2) Suspend the load on the bottom hook.
- (3) Set the changeover knob to (UP), and apply load to the load chain.
(Rotate the feed handle clockwise to remove any slack or twist in the load chain.)
- (4) Clockwise rotation of the lever raises the load chain and the bottom hook.
- (5) Set the changeover knob to (DOWN) and move the lever counterclockwise to lower the load chain and the bottom hook.
- (6) If the lever is heavy when lowering, apply force to the lever only at the beginning of operation.
- (7) After tightening, be sure to set the changeover knob into the (UP) position.
- (8) If the load chain does not move either upward or downward even when lifting/lowering with the lever when no load or a light load is applied, operate while pulling on the load chain lightly without a load. (This is not a malfunction)
- (9) When lifting or lowering, the brake will engage the moment the load is applied.
- (10) When lifting, the mechanical brake rotates while in a tightened condition, immediately supporting the load by means of pawls upon ceasing the lifting operation.
- (11) When lowering, the mechanical brake is loosened corresponding to the amount of lever operation, and the load chain is wound down, with the mechanical brake immediately tightening to support the load when the lowering operation stops.

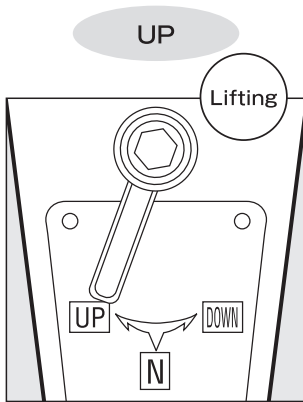

Figure 25

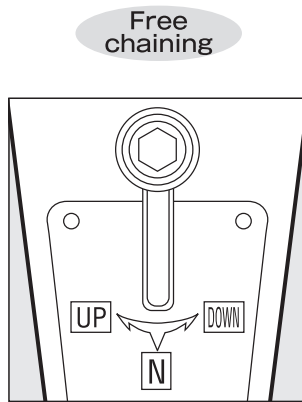

Figure 26

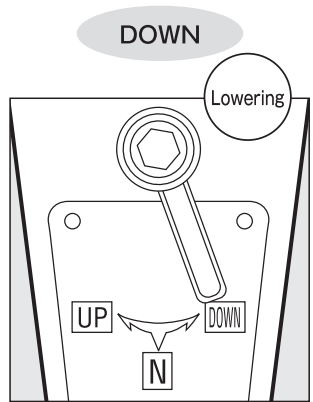

Figure 27

WARNING

- (1) Make sure the location of equipment installation has sufficient strength to support the equipment under load.
- (2) When performing two-hoist lifting, each unit involved in the suspension shall be individually capable of bearing the entire suspended load.
- (3) Never over-wind or over-lower loads.
- (4) Inspect the slings prior to hoisting. Some slinging methods may be extremely dangerous.
- (5) Do not operate the feed handle when lifting or lowering.

CAUTION

- (1) Before lifting/lowering, make sure the hoist is not in free chaining operation, and the changeover knob is set to the correct position.
- (2) If the load chain does not descend upon performing the lowering operation under light load conditions, lightly pull the chain on the load side.

5.4 Overload Protection (Model YAⅢ)

The overload protection device prevents loads in excess of the rated load from being lifted or drawn by letting the lever idle away (slip). (The overload setting cannot be altered.)

DANGER

- (1) Do not lift loads exceeding the rated load.
- (2) If overload protection is activated, stop the lifting operation immediately and unload the load. In such situations, lighten the suspended load or change the capacity of this equipment.
- (3) Do not adjust, modify, or disassemble the overload protection device.
- (4) In case of problems with the overload protection device, replace the device.
- (5) Do not use the overload protection device for unintended purposes including load measurement.

6. Inspection of lever hoists

6.1 Definition

This inspection procedure is compliant with the provisions of the ANSI / ASME B30.21 standard. The following word definitions, considered important, are from ANSI / ASME B30.21 and are relevant to the following inspection procedures:

Inspection criteria reflecting dimensional and geometrical characteristics are provided separately.

●Normal Service

Form of maintenance to be performed on equipment operated with randomly distributed loads within the rated load range and uniform loads of less than 65% of the rated load for 15% or less of the overall usage time.

●Heavy Service

Form of maintenance to be normally performed on equipment used under static loads exceeding the level of normal service.

●Severe Service

Form of maintenance to be performed on equipment subjected to operations exceeding the level of normal or heavy services and exhibiting abnormal behavior.

●Personnel Competence

Personnel performing duties identified within this document shall meet the applicable qualification criteria described in this document.

Additionally, those personnel are required to acquire abilities to perform the duties of the position as determined by the employer or the employer's representative and, where appropriate, to ensure competency based on education, training, experience, skills, and physical fitness.

●Qualified Person

To be in possession of a recognized degree or have certificate of professional standing in the applicable field, or extensive knowledge, training, and experience making one competent to solve job-related problems.

6.2 General

(a) All inspections are to be performed by designated personnel in accordance with the recommendations of the manufacturer and the requirements of this document. Defects identified shall be investigated and determined by qualified personnel as to whether they constitute a hazard and whether or not more detailed inspection or disassembly is required.

(b) Inspection frequency

Inspection intervals shall be determined by a qualified person based on the intended operating conditions and the impact of such conditions on critical hoist components.

6.3 Inspection Category

(a) **Initial inspection:** Hoists to be used for the first time and hoists experiencing repairs and components exchange shall be inspected in accordance with the **routine inspection requirements of Section 6.5.**

(b) **Pre-use inspection:** A visual pre-use inspection, for which no records are required, shall be performed at the beginning of each operation.

(c) **Normal inspection:** A visual inspection for which no records are required.

(1) Normal service: Monthly basis

(2) Heavy service: Weekly to monthly basis

(3) Severe service: Daily to weekly basis

(d) **Routine Inspection:** A documented visual inspection to provide the basis for ongoing evaluation. Coded markings inscribed on the exterior of hoists are acceptable identification in lieu of a record.

(1) Normal service: Annual basis

(2) Heavy Service: Semi-annual basis

(3) Severe service: Quarterly basis

(e) Hoists not in use on a **regular** basis

(1) Hoists unused for a duration of one month or more but less than one year shall be inspected in accordance with the provisions of **Section 6.5** prior to use.

(2) Hoists unused for a duration of one year or more shall be inspected in accordance with the provisions of **Section 6.6** prior to use.

6.4 Pre-use inspections

Minimum inspection requirements include the following items:

(a) Proper operability and appropriate adjustment of the operating mechanism, and any abnormal noise emission.

(b) Routine inspection of hooks in accordance with **ASME B30.10**. (item numbers 10-1.10.3 and 10-2.10.3)

(c) Application of load to the load chain without overall damage. Inspection items (refer to **Section 6.7**.)

(d) Load sheaves, idle wheels

(e) Proper installation of load chain terminal anchorage.

(f) Deformation, cracks, and/or other damage to the hoist unit and levers.

(g) Evidence of damage to the support structure

6.5 Normal inspection

Minimum inspection requirements include the following items:

(a) Proper operability and appropriate adjustment of the operating mechanism, and any abnormal noise emission.

(b) Routine inspection of hooks in accordance with **ASME B30.10**. (item numbers 10-1.10.3 and 10-2.10.3)

(c) Application of load to the load chain without overall damage. Inspection items (refer to **Section 6.7**.)

(d) Load sheaves, idle wheels

(e) Proper installation of load chain terminal anchorage.

(f) Deformation, cracks, and/or other damage to the hoist unit and levers.

(g) Evidence of damage to the support structure

6.6 Routine Inspection

(a) Routine inspections can be performed at the location of usage, and disassembly of the hoist is not necessary.

(b) Covers and other parts of the structure may be released or removed for inspection, but the covers must be closed or replaced before the hoist is restored to its normal state.

(c) Minimum inspection requirements include the following items:

(1) Items listed in section **6.5**

(2) Routine inspection of hooks, including latches, in accordance with ASME B30.10 Hooks (items 10-1.10.4 and 10-2.10.4)

(3) Inspection for loose fasteners including rivets and bolts.

(4) Inspection for wear, corrosion, cracks, and distortion of structural parts.

(5) Damage and wear of load sheaves, idle wheels, etc.

(6) Inspection for traces of worn or oil-contaminated friction discs, worn pawls and ratchet wheels, corroded, stretched or broken pawl springs due to the structure of the friction brake.

(7) Inspection for damage to the support structure.

(8) One or more labels as required under provision ASME B30.21 21-1.1.4 to be intact and clearly visible.

(9) Inspection for deterioration, corrosion, cracks, damage, and deformation of load chain terminal anchorage.

(10) Inspection for missing hoist mounts and hoist fitting mounts.

6.7 Load Chain Inspection

- (a) Load chains should initially be inspected with the hoist suspended in a vertical position and subjected to a load of approximately 50 pounds (23 kg), with the chain integrated into the hoist.
 - (1) With the designated load applied, operate the hoist in both lifting and lowering directions, confirming that the load chains and load sheaves operate to feed the chain smoothly out of the load sheave.
 - (2) If the load chain is tangled, jumpy, or noisy, confirm that the load chain is clean and properly lubricated. If the problem persists, inspect the load chain and mating parts for wear, warping, or other damage.
- (b) Load chains are to be inspected over their entire length for overall damage that may be directly hazardous, such as:
 - (1) Visual inspection for melt damage, weld spatter, corrosion, and deformed links.
 - (2) Verify the smooth feed of load chains back and forth against the sprocket wheels during the lifting and lowering operation under load.
 - (3) Loosen the load chain and move adjacent links to one side, inspecting the contact points for wear.
 - When wear is evident or if elongation deformation is suspected, dimensional measurement of the chain should be performed.
 - Refer to the section on inspection and inspection contents and standard dimensions of load chains concerning the dimensional measurement of load chains.

6.8 Operational Tests

Newly manufactured hoists are tested by the manufacturer.

All hoists experiencing modifications or repairs, as well as previously used hoists that have not been operated within 12 months, are to be tested by, or under the direction of designated personnel, to ensure compliance with the requirements of this instruction manual.

- (a) All functions of the hoist are to be confirmed with the hoist suspended under no load. (Some hoists require the application of their rated load or manual pulling on the hook to test the lowering action.)
- (b) After the no-load test, 100 pounds (46kg) per load chain should be loaded to confirm the braking control capability.

6.9 Load Tests

- (a) New hoists are tested by the manufacturer with a test load of at least 125% of the rated load.
- (b) Hoists experiencing modifications, replacements or repairs to load-bearing components are to be statically or dynamically load tested.
 - (1) The need for load testing of the hoist is to be determined by qualified persons.
 - (2) A written report of the test must be prepared and kept on file.
 - (3) The test load must not exceed 100% of the rated load of the hoist, or 125% of the rated load of the hoist.
 - (4) Load chain replacement is specifically excluded from this load test. However, hoist operation testing is to be conducted in accordance with the provisions of Section **6.8**.
- (c) The test location and hoisting method needs to be approved by a qualified person.

6.10 Inspection, Testing Methods and Reference Values

Inspection/testing method and standard values are as follows:

Inspection and testing methods for YA parts (*Refer to the breakdown schematics for part numbers.)

※Although details of inspection and limit dimensions are specified for respective parts, users should determine the frequency of use and duration of service individually, replacing the necessary parts with new parts or new products in order to prevent accidents and enhance the operational safety factor.

※Please note, some of the parts are forged and may have slight dimensional errors.

The following dimensions are limit values based on reference standard values.

Inspection item (part name) part number	Method	Inspection/test details/standard values	Measures
Top hook ass'y (NO.1)	Visual inspection, measurement	Inspect opening of the hook, hook thickness and wear in vertical/horizontal dimensions Inspect diameter of the top hook pin-hole for elongation Inspect the hook for bends, twists, damage, etc. and smooth hook rotation Dimensions are not to exceed the reference standard values.	Replace with a new part.

Table 6

Rated load	Position	Reference standard values	Enter actual measured value at the time of purchase
0.8t 1763lbs	A : Between punches	46.6mm 1.83in	Not to exceed dimension A
	B : Hook thickness, vertical	19.0mm 0.74in	18.0mm 0.70in
	C : Hook thickness, horizontal	15.0mm 0.59in	14.2mm 0.55in
	D : Hole diameter, top hook pin	12.5mm 0.49in	13.1mm 0.51in
1t 2204lbs	A : Between punches	51.0mm 2.00in	Not to exceed dimension A
	B : Hook thickness, vertical	22.0mm 0.86in	20.9mm 0.82in
	C : Hook thickness, horizontal	16.0mm 0.62in	15.2mm 0.59in
	D : Hole diameter, top hook pin	12.5mm 0.49in	13.1mm 0.51in
1.6t 3527lbs	A : Between punches	55.0mm 2.16in	Not to exceed dimension A
	B : Hook thickness, vertical	26.0mm 1.02in	24.7mm 0.97in
	C : Hook thickness, horizontal	21.0mm 0.82in	19.9mm 0.78in
	D : Hole diameter, top hook pin	14.5mm 0.57in	15.2mm 0.59in
3.2t 7054lbs	A : Between punches	67.0mm 2.63in	Not to exceed dimension A
	B : Hook thickness, vertical	35.0mm 1.37in	33.2mm 1.30in
	C : Hook thickness, horizontal	28.0mm 1.10in	26.6mm 1.04in
	D : Hole diameter, top hook pin	16.5mm 0.64in	17.3mm 0.68in
6.3t 13889lbs	A : Between punches	91.5mm 3.60in	Not to exceed dimension A
	B : Hook thickness, vertical	46.0mm 1.81in	43.7mm 1.72in
	C : Hook thickness, horizontal	34.0mm 1.33in	32.3mm 1.27in
	D : Hole diameter, top hook pin	16.5mm 0.64in	17.3mm 0.68in
9t 19841lbs	A : Between punches	125.0mm 4.92in	Not to exceed dimension A
	B : Hook thickness, vertical	61.1mm 2.40in	58.0mm 2.28in
	C : Hook thickness, horizontal	47.5mm 1.87in	45.1mm 1.77in
	D : Hole diameter, top hook pin	16.5mm 0.64in	17.3mm 0.68in

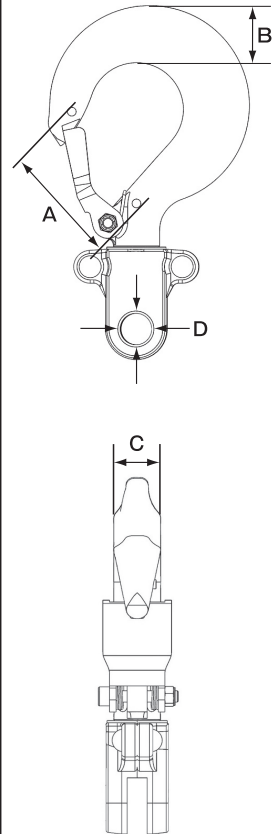

Figure 28

Dimension A is not to exceed dimension A value.
Actual measured values of dimensions B, C, and D are not to indicate wear of 5% or more.

Inspection item (part name) part number	Method	Inspection/test details/standard values		Measures
Safety latch set (NO.2)	Visual inspection, measurement	Confirm engagement with the hook, the repulsive force of the spring, and if there is any damage or deformation.		Replace with a new part.
	Table 7			
Rated load	Engraving	Dimension A	Dimension B	
0.8t 1763lbs	C-3	45.0mm	22.0mm	
		1.77in	0.86in	
1t 2204lbs	F-4	48.0mm	22.0mm	
		1.88in	0.86in	
1.6t 3527lbs	F-5	54.0mm	31.0mm	
		2.12in	1.22in	
3.2t 7054lbs	C-8	66.5mm	37.2mm	
		2.61in	1.46in	
6.3t 13889lbs	5.0	82.0mm	45.0mm	
		3.22in	1.77in	
9t 19841lbs	C10	109.5mm	60.0mm	
		4.31in	2.36in	

Figure 29

Inspection item (part name) part number	Method	Inspection/test details/standard values	Measures
Bottom hook ass'y (NO.7)	Visual inspection	Inspect the opening of the hook, hook thickness and wear in vertical/horizontal dimensions, elongation of the chain retaining bolt hole Inspect the hook for bends, twists, damage, etc. and smooth hook rotation Dimensions are not to exceed the reference standard values.	Replace with a new part.

Table 8

Rated load	Position	Reference standard values	Enter actual measured value at the time of purchase
0.8t 1763lbs	A : Between punches	46.6mm 1.83in	Not to exceed dimension A
	B : Hook thickness, vertical	19.0mm 0.74in	18.0mm 0.70in
	C : Hook thickness, horizontal	15.0mm 0.59in	14.2mm 0.55in
	D : Chain stop bolt hole diameter	8.8mm 0.34in	9.3mm 0.35in
1t 2204lbs	A : Between punches	51.0mm 2.00in	Not to exceed dimension A
	B : Hook thickness, vertical	22.0mm 0.86in	20.9mm 0.82in
	C : Hook thickness, horizontal	16.0mm 0.62in	15.2mm 0.59in
	D : Chain stop bolt hole diameter	8.8mm 0.34in	9.3mm 0.35in
1.6t 3527lbs	A : Between punches	55.0mm 2.16in	Not to exceed dimension A
	B : Hook thickness, vertical	26.0mm 1.02in	24.7mm 0.97in
	C : Hook thickness, horizontal	21.0mm 0.82in	19.9mm 0.78in
	D : Chain stop bolt hole diameter	10.8mm 0.42in	11.3mm 0.43in
3.2t 7054lbs	A : Between punches	67.0mm 2.63in	Not to exceed dimension A
	B : Hook thickness, vertical	35.0mm 1.37in	33.2mm 1.30in
	C : Hook thickness, horizontal	28.0mm 1.10in	26.6mm 1.04in
	D : Chain stop bolt hole diameter	12.7mm 0.5in	13.2mm 0.51in
6.3t 13889lbs	A : Between punches	91.5mm 3.60in	Not to exceed dimension A
	B : Hook thickness, vertical	46.0mm 1.81in	43.7mm 1.72in
	C : Hook thickness, horizontal	34.0mm 1.33in	32.3mm 1.27in
	D : Chain stop bolt hole diameter	12.7mm 0.5in	13.2mm 0.51in
9t 19841lbs	A : Between punches	125.0mm 4.92in	Not to exceed dimension A
	B : Hook thickness, vertical	61.1mm 2.40in	58.0mm 2.28in
	C : Hook thickness, horizontal	47.5mm 1.87in	45.1mm 1.77in
	D : Chain stop bolt hole diameter	13.4mm 0.52in	13.9mm 0.53in

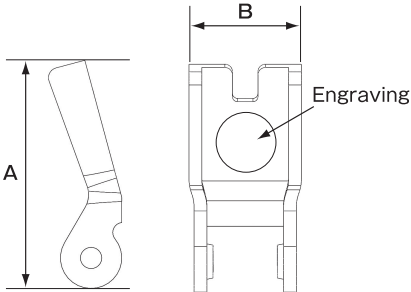
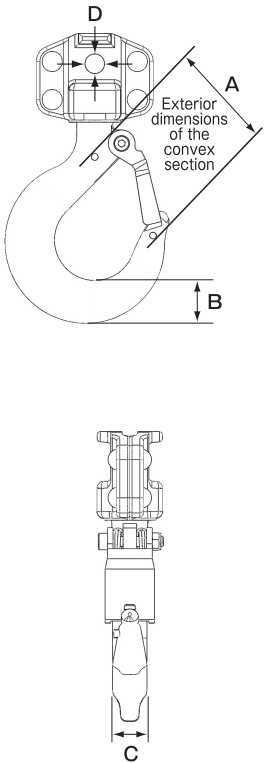
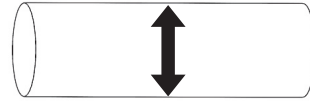

Figure 30

Dimension A is not to exceed dimension A value.
Dimensions B and C are not to indicate wear of 5% or more in relation to the actual measured value.
Dimension D is not to indicate wear of 0.5 mm (0.01 in) or more in relation to the above reference standard value.

Inspection item (part name) part number	Method	Inspection/test details/standard values	Measures
Top hook pin (NO.6)	Visual inspection, measurement Table 9	Inspect for pin diameter wear.	Replace with a new part.
Rated load	Dimension A reference standard value	Limit value	
0.8t 1763lbs	12mm	11.4mm	
	0.47in	0.44in	
1t 2204lbs	12mm	11.4mm	
	0.47in	0.44in	
1.6t 3527lbs	14mm	13.3mm	
	0.55in	0.52in	
3.2t 7054lbs	16mm	15.2mm	
	0.62in	0.59in	
6.3t 13889lbs	16mm	15.2mm	
	0.62in	0.59in	
9t 19841lbs	16mm	15.2mm	
	0.62in	0.59in	



Dimension A

Figure 31

Not to indicate wear of 5% or more in relation to above dimensional value.

Inspection item (part name) part number	Method	Inspection/test details/standard values	Measures																																																										
Chain stop bolt set (NO.8)	Visual inspection	Inspect for wear of the chain stop bolt diameter; damage or deformation of the retaining bolt; cracks in the hex. castle nut Deterioration of the cotter pin	Replace with a new part. ※Periodic replacement is recommended																																																										
	<table border="1"> <thead> <tr> <th>Rated load</th> <th>Dimension A</th> <th>Dimension A limit value</th> <th>Dimension B</th> <th>Dimension C</th> <th>Engraving</th> </tr> </thead> <tbody> <tr> <td rowspan="2">0.8t 1763lbs</td> <td>8.5mm</td> <td>8.0mm</td> <td>23.0mm</td> <td rowspan="2">M6XP1</td> <td rowspan="2">EF</td> </tr> <tr> <td>0.33in</td> <td>0.32in</td> <td>0.90in</td> </tr> <tr> <td rowspan="2">1t 2204lbs</td> <td>8.5mm</td> <td>8.0mm</td> <td>23.0mm</td> <td rowspan="2">M6XP1</td> <td rowspan="2">EF</td> </tr> <tr> <td>0.33in</td> <td>0.32in</td> <td>0.90in</td> </tr> <tr> <td rowspan="2">1.6t 3527lbs</td> <td>10.5mm</td> <td>10.0mm</td> <td>29.5mm</td> <td rowspan="2">M8XP1.25</td> <td rowspan="2">EH</td> </tr> <tr> <td>0.41in</td> <td>0.40in</td> <td>1.16in</td> </tr> <tr> <td rowspan="2">3.2t 7054lbs</td> <td>12.5mm</td> <td>12.0mm</td> <td>39.0mm</td> <td rowspan="2">M10XP1.5</td> <td rowspan="2">EK</td> </tr> <tr> <td>0.49in</td> <td>0.47in</td> <td>1.53in</td> </tr> <tr> <td rowspan="2">6.3t 13889lbs</td> <td>12.5mm</td> <td>12.0mm</td> <td>39.0mm</td> <td rowspan="2">M10XP1.5</td> <td rowspan="2">EK</td> </tr> <tr> <td>0.49in</td> <td>0.48in</td> <td>1.53in</td> </tr> <tr> <td rowspan="2">9t 19841lbs</td> <td>13.0mm</td> <td>12.5mm</td> <td>48.0mm</td> <td rowspan="2">M12XP1.75</td> <td rowspan="2">None</td> </tr> <tr> <td>0.51in</td> <td>0.50in</td> <td>1.88in</td> </tr> </tbody> </table>		Rated load	Dimension A	Dimension A limit value	Dimension B	Dimension C	Engraving	0.8t 1763lbs	8.5mm	8.0mm	23.0mm	M6XP1	EF	0.33in	0.32in	0.90in	1t 2204lbs	8.5mm	8.0mm	23.0mm	M6XP1	EF	0.33in	0.32in	0.90in	1.6t 3527lbs	10.5mm	10.0mm	29.5mm	M8XP1.25	EH	0.41in	0.40in	1.16in	3.2t 7054lbs	12.5mm	12.0mm	39.0mm	M10XP1.5	EK	0.49in	0.47in	1.53in	6.3t 13889lbs	12.5mm	12.0mm	39.0mm	M10XP1.5	EK	0.49in	0.48in	1.53in	9t 19841lbs	13.0mm	12.5mm	48.0mm	M12XP1.75	None	0.51in	0.50in
Rated load	Dimension A	Dimension A limit value	Dimension B	Dimension C	Engraving																																																								
0.8t 1763lbs	8.5mm	8.0mm	23.0mm	M6XP1	EF																																																								
	0.33in	0.32in	0.90in																																																										
1t 2204lbs	8.5mm	8.0mm	23.0mm	M6XP1	EF																																																								
	0.33in	0.32in	0.90in																																																										
1.6t 3527lbs	10.5mm	10.0mm	29.5mm	M8XP1.25	EH																																																								
	0.41in	0.40in	1.16in																																																										
3.2t 7054lbs	12.5mm	12.0mm	39.0mm	M10XP1.5	EK																																																								
	0.49in	0.47in	1.53in																																																										
6.3t 13889lbs	12.5mm	12.0mm	39.0mm	M10XP1.5	EK																																																								
	0.49in	0.48in	1.53in																																																										
9t 19841lbs	13.0mm	12.5mm	48.0mm	M12XP1.75	None																																																								
	0.51in	0.50in	1.88in																																																										
<p style="text-align: center;">Figure 32</p>																																																													
Wear shall not 0.5 mm (0.01 in) or more of the above dimensional value																																																													
Hex. nut (NO.13)	Visual inspection	Inspect for damage, wear, deformation, etc.	Replace with a new part.																																																										
Spring washer (NO.14)	Visual inspection	Inspect for damage, wear, deformation, etc.	Replace with a new part.																																																										
Gear cover ass'y (NO.18)	Visual inspection	Inspect for significant deformation and wear with bumps identifiable by hand. Inspect for cracks, wear, or rattling of the metal clasped to the gear cover.	Replace with a new part.																																																										
				<p style="text-align: right;">Figure 33</p>																																																									
Pinion shaft (NO.19)	Visual inspection	Inspect for chipped gear teeth, bumpy wear or damage, and smooth rotation of the gear when passing through the disc hub and feed gear.	Replace with a new part.																																																										
Washer for pinion shaft (NO.20)	Visual inspection	Inspect for significant deformation, wear with bumps identifiable by hand.	Replace with a new part.																																																										
Hex. castle nut (NO.21)	Visual inspection	Inspect for damage, wear, deformation, etc.	Replace with a new part.																																																										
Cotter pin (NO.22)	Visual inspection	Inspect for damage, wear, deformation, etc.	Replace with a new part.																																																										
2nd and 3rd gear ass'y (NO.23)	Visual inspection	Inspect for chipped gear teeth, bumpy wear or damage	Replace with a new part.																																																										

Inspection item (part name) part number	Method	Inspection/test details/standard values	Measures
Load gear (NO.24)	Visual inspection	Inspect for chipped gear teeth, bumpy wear or damage	Replace with a new part.
Load sheave (NO.25)	Visual inspection	Inspect for bumpy wear, damage, deformation, etc., on parts engaging the chain (pocket). Inspect for signs of obduction by the chain Locations with possibility of being obducted by the chain	Replace with a new part.  Figure 34
Chain guide ass'y (NO.26)	Visual inspection	Inspect for bumpy wear, damage and signs of obduction by the chain	Replace with a new part.
Chain stripper (NO.27)	Visual inspection	Inspect for bumpy wear, damage and signs of obduction by the chain	Replace with a new part.
Disk hub (NO.28)	Visual inspection	Inspect for chipped gear teeth, bumpy wear and damage; smooth rotation when the pinion shaft is passed through.	Replace with a new part.
E-ring for disc hub (NO.29)	Visual inspection	Inspect for opening of ring and damage	Replace with a new part.
Ratchet wheel (NO.30)	Visual inspection	Inspect for chipped teeth, wear in positions engaging the pawls, damage Braking section to be free of any bumpy wear	Replace with a new part.

Table 11

Rated load	Dimension A	Dimension A limit value
0.8t 1763lbs	66.0mm	62.7mm
	2.59in	2.46in
1t 2204lbs	66.0mm	62.7mm
	2.59in	2.46in
1.6t 3527lbs	72.0mm	68.4mm
	2.83in	2.68in
3.2t 7054lbs	72.0mm	68.4mm
	2.83in	2.68in
6.3t 13889lbs	72.0mm	68.4mm
	2.83in	2.68in
9t 19841lbs	72.0mm	68.4mm
	2.83in	2.68in

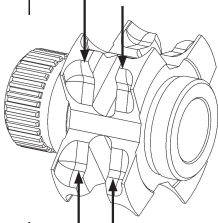
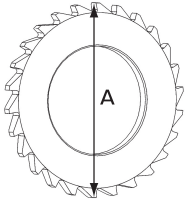

Dimension A :
Ratchet wheel diameter

Figure 35

Not to indicate wear of 5% or more in relation to above dimensional value.

Inspection item (part name) part number	Method	Inspection/test details/standard values	Measures
Brake lining (NO.31)	Visual inspection	Inspect for chipped teeth, wear in positions engaging the pawls, damage Braking section to be free of any bumpy wear	Replace with a new part.

Table 12

Rated load	Dimension A	Dimension A limit value	Dimension B	Dimension C
0.8t 1763lbs	3.0mm	2.8mm	55.0mm	34.5mm
	0.118in	0.110in	2.16in	1.35in
1t 2204lbs	3.0mm	2.8mm	55.0mm	34.5mm
	0.118in	0.110in	2.16in	1.35in
1.6t 3527lbs	3.5mm	3.3mm	64.0mm	40.5mm
	0.13in	0.12in	2.51in	1.59in
3.2t 7054lbs	3.5mm	3.3mm	64.0mm	40.5mm
	0.13in	0.12in	2.51in	1.59in
6.3t 13889lbs	3.5mm	3.3mm	64.0mm	40.5mm
	0.13in	0.12in	2.51in	1.59in
9t 19841lbs	3.5mm	3.3mm	64.0mm	40.5mm
	0.13in	0.12in	2.51in	1.59in

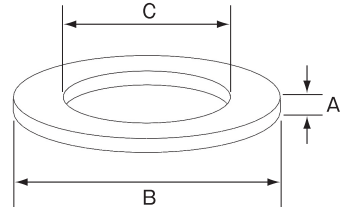

Figure 36

To be free of wear deviating 0.2mm or more from the dimensional value above

Lever ass'y (NO.33)	Visual inspection	Inspect for significant deformation and normal movement of the changeover knob.	Replace with a new part.
Lever grip (NO.34)	Visual inspection	Inspect for cracks in the rubber handle, deformation, etc.	Replace with a new part.
Bracket screw (NO.35)	Visual inspection	Inspect for attachment of bracket screws	Replace with a new part.
Name plate (NO.92)	Visual inspection	Inspect for damage, legibility	Replace with a new part.
Hex. nut (NO.36)	Visual inspection	Inspect for damage, wear, deformation, etc.	Replace with a new part.
Spring washer (NO.37)	Visual inspection	Inspect for damage, wear, deformation, etc.	Replace with a new part.
Feed gear (NO.38)	Visual inspection	Inspect for chipped gear teeth, bumpy wear and damage Inspect for smooth rotation when the pinion shaft is passed through	Replace with a new part.
Ratchet for feed gear (NO.39)	Visual inspection	Inspect for significant deformation and wear with bumps identifiable by hand.	Replace with a new part.
Ratchet spring pin (NO.40)	Visual inspection	Inspect for damage, deformation and wear	Replace with a new part.

Inspection item (part name) part number	Method	Inspection/test details/standard values	Measures
Lever cover set (NO.43)	Visual inspection	Inspect for any significant deformation and catching in the rotating parts.	Replace with a new part.
Gear-side plate ass'y (NO.82)	Visual inspection	Inspect for damage or deformation of the top hook pin hole, sheave hole, and stay bolt.	Replace with a new part.

Table 13

Rated load	Dimension A	Dimension A limit value
0.8t 1763lbs	12.5mm	13.0mm
	0.49in	0.50in
1t 2204lbs	12.5mm	13.0mm
	0.49in	0.50in
1.6t 3527lbs	14.5mm	15.0mm
	0.57in	0.58in
3.2t 7054lbs	16.5mm	17.0mm
	0.64in	0.65in
6.3t 13889lbs	16.5mm	17.0mm
	0.64in	0.65in
9t 19841lbs	16.5mm	17.0mm
	0.64in	0.65in

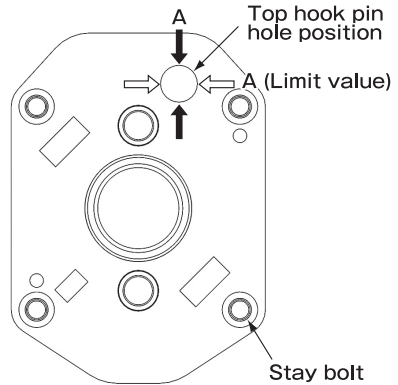

Figure 37

To be without wear of 0.5 mm (0.01 in) or more in relation to the above dimensional value. Measurement to be taken at 90° angles horizontally and vertically.

Lever-side plate ass'y (NO.83)	Visual inspection	Inspect for damage or deformation of the top hook pin hole and sheave hole.	Replace with a new part.
--------------------------------	-------------------	---	--------------------------

Table 14

Rated load	Dimension A	Dimension A limit value
0.8t 1763lbs	12.5mm	13.0mm
	0.49in	0.50in
1t 2204lbs	12.5mm	13.0mm
	0.49in	0.50in
1.6t 3527lbs	14.5mm	15.0mm
	0.57in	0.58in
3.2t 7054lbs	16.5mm	17.0mm
	0.64in	0.65in
6.3t 13889lbs	16.5mm	17.0mm
	0.64in	0.65in
9t 19841lbs	16.5mm	17.0mm
	0.64in	0.65in

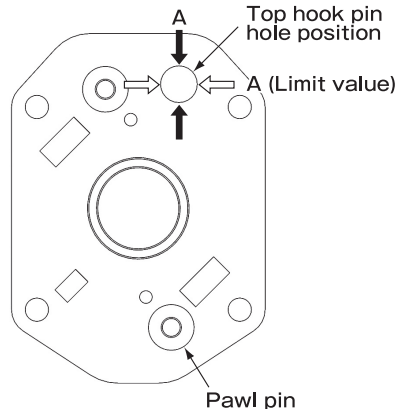

Figure 38

To be without wear of 0.5 mm (0.01 in) or more in relation to the above dimensional value. Measurement to be taken at 90° angles horizontally and vertically.

Inspection item (part name) part number	Method	Inspection/test details/standard values	Measures
Pawl (NO.15)	Visual inspection	Inspect for chipped teeth on pawls, bumpy wear and damage	Replace with a new part.
Pawl spring (NO.16)	Visual inspection	To be without wear on the surfaces contacting the pawls. Bending portion of the spring to be free of indicate cracks or breaks. Spring to be free of expansion/contraction or deformation due to compression.	Replace with a new part.
E-ring for pawl (NO.17)	Visual inspection	Inspect for opening of ring and damage	Replace with a new part.
Ratchet spring (NO.85)	Visual inspection	Inspect for expansion/contraction beyond the specified value.	Replace with a new part.

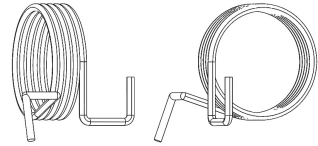

Figure 39

Table 15

Rated load	Dimension A reference standard value	To be without expansion/contraction beyond the dimension indicated on the left (to be without deformation due to compression)
0.8t 1763lbs	35mm	
	1.37in	
1t 2204lbs	35mm	
	1.37in	
1.6t 3527lbs	48mm	
	1.88in	
3.2t 7054lbs	48mm	
	1.88in	
6.3t 13889lbs	48mm	
	1.88in	
9t 19841lbs	48mm	
	1.88in	

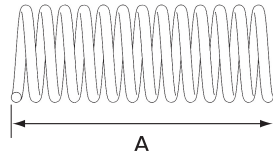

Figure 40

Inspection item (part name) part number	Method	Inspection/test details/standard values	Measures
Spring for floating mechanism (NO.87)	Visual inspection	Inspect for expansion/contraction beyond the specified value.	Replace with a new part.

Table 16

Rated load	Dimension A reference standard value	To be without expansion/contraction beyond the dimension indicated on the left (to be without deformation due to compression)
0.8t	32.5mm	
1763lbs	1.27in	
1t	32.5mm	
2204lbs	1.27in	
1.6t	38.5mm	
3527lbs	1.51in	
3.2t	42.0mm	
7054lbs	1.65in	
6.3t	42.0mm	
13889lbs	1.65in	
9t	42.0mm	
19841lbs	1.65in	

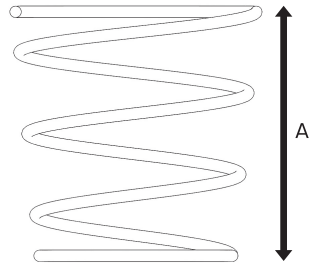

Figure 41

Feed handle (NO.88)	Visual inspection	To be without damage or deformation	Replace with a new part.
Chain stopper (NO.91)	Visual inspection, measurement	Inspect for expansion/contraction beyond the specified value.	Replace with a new part.

Table 17

Rated load	A	B	C	To be without expansion/contraction beyond the dimension indicated on the left (to be without deformation due to compression)
0.8t	50mm	20mm	1mm	
1763lbs	1.96in	0.78in	0.03in	
1t	50mm	20mm	1mm	
2204lbs	1.96in	0.78in	0.03in	
1.6t	63mm	26mm	1mm	
3527lbs	2.48in	1.02in	0.03in	
3.2t	79mm	34mm	1mm	
7054lbs	3.11in	1.33in	0.03in	
6.3t	79mm	34mm	1mm	
13889lbs	3.11in	1.33in	0.03in	
9t	79mm	34mm	1mm	
19841lbs	3.11in	1.33in	0.03in	

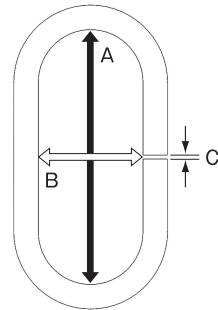
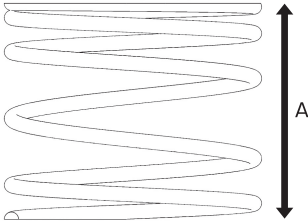

Figure 42

Check washer (NO.102)	Visual inspection	Inspect for significant deformation, wear with bumps identifiable by hand.	Replace with a new part.
Hex. socket head cap screw set (NO.103)	Visual inspection	Inspect for damage, deformation and wear	Replace with a new part.
Tag (NO.110)	Visual inspection	Inspect for damage, deformation and wear	Replace with a new part.

Inspect and test Model YAⅢ parts indicated below:

Inspection item (part name) part number	Method	Inspection/test details/standard values	Measures		
TORCON device set for Model YAⅢ (NO.238)	Visual inspection	Inspect for chipped gear teeth, bumpy wear and damage Inspect for smooth rotation when the pinion shaft is passed through	Replace with a new part.		
Spring for floating mechanism for Model YAⅢ (NO.287)	Visual inspection, measurement	Inspect for expansion/contraction beyond the specified value.	Replace with a new part.		
Table 18					
Rated load	Dimension A reference standard value	To be without expansion/contraction beyond the dimension indicated on the left (to be without deformation due to compression)	 <p style="text-align: center;">Figure 43</p>		
0.8t 1763lbs	22mm 0.86in				
1t 2204lbs	22mm 0.86in				
1.6t 3527lbs	24mm 0.94in				
3.2t 7054lbs	24mm 0.94in				
6.3t 13889lbs	24mm 0.94in				
9t 19841lbs	24mm 0.94in				
Feed handle for Model YAⅢ (NO.288)	Visual inspection			To be without damage or deformation	Replace with a new part.
Hex. socket head cap screw set for Model YAⅢ (NO.203)	Visual inspection			Inspect for damage, deformation and wear	Replace with a new part.
Name plate for Model YAⅢ (NO.292)	Visual inspection			Inspect for damage, legibility	Replace with a new part.

※Parts other than the above are in common with Model YA.

Inspect and test Model YAS parts indicated below:

Inspection Items /Points	Inspection contents/methods	Countermeasure
--------------------------	-----------------------------	----------------

Top hook ass'y

Inspect opening of the hook, hook thickness and wear in vertical/horizontal dimensions; diameter of the top hook pin-hole for elongation
 Inspect the hook for bends, twists, damage, etc. and smooth hook rotation.
 Dimensions are not to exceed the reference standard values.

Replace with a new part.

Table 19

Rated load	Position	Reference standard values	Enter actual measured values at the time of purchase.
0.8t 1763lbs	A : Between punches	54.0mm 21.2in	Not to exceed dimension A
	B : Hook thickness, vertical	23.5mm 0.92in	22.3mm 0.87in
	C : Hook thickness, horizontal	19.0mm 0.74in	18mm 0.70in
	D : Hole diameter, top hook pin	12.5mm 0.49in	13.1mm 0.51in
1t 2204lbs	A : Between punches	54.0mm 21.2in	Not to exceed dimension A
	B : Hook thickness, vertical	23.5mm 0.92in	22.3mm 0.87in
	C : Hook thickness, horizontal	19.0mm 0.74in	18mm 0.70in
	D : Hole diameter, top hook pin	12.5mm 0.49in	13.1mm 0.51in
1.6t 3527lbs	A : Between punches	55.0mm 2.16in	Not to exceed dimension A
	B : Hook thickness, vertical	28.5mm 1.12in	27.0mm 1.06in
	C : Hook thickness, horizontal	23.0mm 0.90in	21.8mm 0.85in
	D : Hole diameter, top hook pin	14.5mm 0.57in	15.2mm 0.59in
3.2t 7054lbs	A : Between punches	70.2mm 2.76in	Not to exceed dimension A
	B : Hook thickness, vertical	37.0mm 1.45in	35.1mm 1.38in
	C : Hook thickness, horizontal	28.0mm 1.10in	26.6mm 1.04in
	D : Hole diameter, top hook pin	16.5mm 0.64in	17.3mm 0.68in

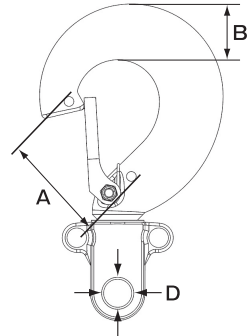

Dimension A is not to exceed dimension A value.
 Actual measured values of dimensions B, C, and D are not to indicate wear of 5% or more.

※Parts other than the hook section are in common with Model YA.

Figure 44

Inspection Items /Points	Inspection contents/methods	Countermeasure
Safety latch set	Confirm engagement with hook, the repulsive force of the spring, and if there is any damage or deformation	Replace with a new part.

Table 20

Rated load	Dimension A	Dimension B	Dimension C
0.8t 1763lbs	55.5mm	23.5mm	30.5mm
	2.18in	0.92in	12.0in
1t 2204lbs	55.5mm	23.5mm	30.5mm
	2.18in	0.92in	12.0in
1.6t 3527lbs	55.5mm	23.5mm	30.5mm
	2.18in	0.92in	12.0in
3.2t 7054lbs	72.0mm	28.0mm	35.0mm
	2.83in	1.10in	1.37in

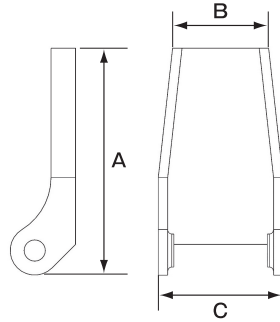

Figure 45

Bottom hook ass'y	Inspect opening of the hook, hook thickness and wear in vertical/horizontal dimensions: diameter of the chain retainer bolt-hole for elongation Inspect the hook for bends, twists, damage, etc. and smooth hook rotation. Dimensions are not to exceed the reference standard values.	Replace with a new part.
-------------------	--	--------------------------

Table 21

Rated load	Position	Reference standard values	Enter actual measured values at the time of purchase
0.8t 1763lbs	A : Between punches	54.0mm	Not to exceed dimension A
		21.2in	
	B : Hook thickness, vertical	23.5mm	22.3mm
		0.92in	0.87in
	C : Hook thickness, horizontal	19.0mm	18mm
	0.74in	0.70in	
1t 2204lbs	A : Between punches	54.0mm	Not to exceed dimension A
		21.2in	
	B : Hook thickness, vertical	23.5mm	22.3mm
		0.92in	0.87in
	C : Hook thickness, horizontal	19.0mm	18mm
	0.74in	0.70in	
1.6t 3527lbs	A : Between punches	55.0mm	Not to exceed dimension A
		2.16in	
	B : Hook thickness, vertical	28.5mm	27.0mm
		1.12in	1.06in
	C : Hook thickness, horizontal	23.0mm	21.8mm
	0.90in	0.85in	
3.2t 7054lbs	A : Between punches	70.2mm	Not to exceed dimension A
		2.76in	
	B : Hook thickness, vertical	37.0mm	35.1mm
		1.45in	1.37in
	C : Hook thickness, horizontal	28.0mm	26.6mm
	1.10in	1.04in	
	D : Chain stop bolt hole diameter	12.7mm	13.2mm
		0.5in	0.51in

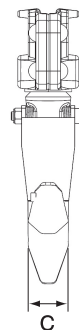
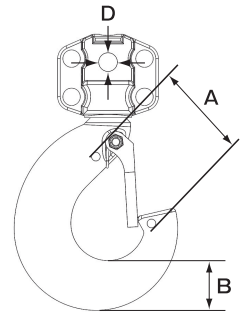

Figure 46

Dimension A is not to exceed dimension A value.
Dimensions B, and C are not to indicate wear of 5% or more in relation to the actual measured value.
Dimension D is not to indicate wear of 0.5 mm (0.01 in) or more in relation to the above reference standard value.
*Parts other than the hook section are in common with Model YA.

Inspect and test Model YAR parts indicated below:

Inspection Items /Points	Inspection contents/methods	Countermeasure
Top hook ass'y	Inspect opening of the hook, hook thickness and wear in vertical/horizontal dimensions: diameter of the top hook pin-hole for elongation Inspect the hook for bends, twists, damage, etc. and smooth hook rotation. Dimensions are not to exceed the reference standard values.	Replace with a new part.

Table 22

Rated load	Position	Reference standard values	Enter actual measured values at the time of purchase.
0.8t 1763lbs	A : Interior dimensions of the hook	29.5mm 1.16in	Not to exceed dimension A
	B : Hook thickness, vertical	19.5mm 0.76in	18.5mm 0.72in
	C : Hook thickness, horizontal	14.0mm 0.55in	13.3mm 0.52in
	D : Hole diameter, top hook pin	12.5mm 0.49in	13.1mm 0.51in
1t 2204lbs	A : Interior dimensions of the hook	29.5mm 1.16in	Not to exceed dimension A
	B : Hook thickness, vertical	19.5mm 0.76in	18.5mm 0.72in
	C : Hook thickness, horizontal	14.0mm 0.55in	13.3mm 0.52in
	D : Hole diameter, top hook pin	12.5mm 0.49in	13.1mm 0.51in
1.6t 3527lbs	A : Interior dimensions of the hook	47.0mm 1.85in	Not to exceed dimension A
	B : Hook thickness, vertical	28.5mm 1.12in	27.0mm 1.06in
	C : Hook thickness, horizontal	24.0mm 0.94in	22.8mm 0.89in
	D : Hole diameter, top hook pin	14.5mm 0.57in	15.2mm 0.59in
3.2t 7054lbs	A : Interior dimensions of the hook	52.0mm 2.04in	Not to exceed dimension A
	B : Hook thickness, vertical	39.0mm 1.53in	37.0mm 1.45in
	C : Hook thickness, horizontal	28.0mm 1.10in	26.6mm 1.04in
	D : Hole diameter, top hook pin	16.5mm 0.64in	17.3mm 0.68in

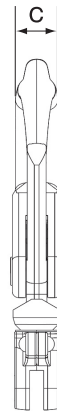
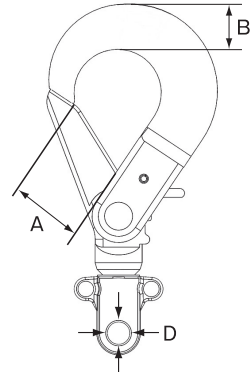

Dimension A is not to exceed dimension A value. Actual measured values of dimensions B, C, and D are not to indicate wear of 5% or more.

※Parts other than the hook section are in common with Model YA.

Figure 47

Inspection Items /Points	Inspection contents/methods	Countermeasure
Trigger	Confirm hook engagement, the repulsive force of the spring, and if there is any damage or deformation	Replace with a new part.
Bottom hook ass'y	Inspect the hook opening, hook thickness, and wear in vertical/horizontal dimensions; Check for elongation of the chain stop bolt-hole Inspect the hook for bends, twists, damage, etc. and smooth hook rotation. Dimensions are not to exceed the reference standard values.	Replace with a new part.

Table 23

Rated load	Position	Reference standard values	Enter actual measured values at the time of purchase.
0.8t 1763lbs	A : Interior dimensions of the hook	29.5mm 1.16in	Not to exceed dimension A
	B : Hook thickness, vertical	19.5mm 0.76in	22.3mm 0.87in
	C : Hook thickness, horizontal	14.0mm 0.55in	18mm 0.70in
	D : Chain stop bolt hole diameter	8.8mm 0.34in	9.3mm 0.35in
	A : Interior dimensions of the hook	29.5mm 1.16in	Not to exceed dimension A
1 t 2204lbs	B : Hook thickness, vertical	19.5mm 0.76in	22.3mm 0.87in
	C : Hook thickness, horizontal	14.0mm 0.55in	18mm 0.70in
	D : Chain stop bolt hole diameter	8.8mm 0.34in	9.3mm 0.35in
	A : Interior dimensions of the hook	47.0mm 1.85in	Not to exceed dimension A
	B : Hook thickness, vertical	28.5mm 1.12in	27.0mm 1.06in
1.6t 3527lbs	C : Hook thickness, horizontal	24.0mm 0.94in	21.8mm 0.85in
	D : Chain stop bolt hole diameter	10.8mm 0.42in	11.3mm 0.43in
	A : Interior dimensions of the hook	52.0mm 2.04in	Not to exceed dimension A
	B : Hook thickness, vertical	39.0mm 1.53in	35.1mm 1.37in
	C : Hook thickness, horizontal	28.0mm 1.10in	26.6mm 1.04in
3.2t 7054lbs	D : Chain stop bolt hole diameter	12.7mm 0.5in	13.2mm 0.51in

Dimension A is not to exceed dimension A value. Dimensions B and C are not to indicate wear of 5% or more in relation to the actual measured value. Dimension D is not to indicate wear of 0.5 mm (0.01 in) or more in relation to the above reference standard value.

※Parts other than the hook section are in common with Model YA.

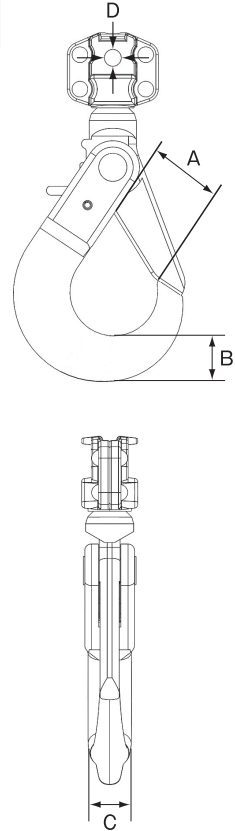

Figure 48

Inspection item (part name) part number	Method	Inspection/test details/standard values	Measures
Load chain (NO.53)	Visual inspection	Inspect for any damage, deformation, or elongation beyond the specified value	Replace with a new part.

Table 24

Rated load	Diameter (mm)		Pitch (P×5) (mm)	
	Standard value	Limit value	Standard value	Limit value
0.8t 1763lbs	5.6mm	5.3mm	85.6mm	88.2mm
	0.22in	0.20in	3.37in	3.47in
1t 2204lbs	5.6mm	5.3mm	85.6mm	88.2mm
	0.22in	0.20in	3.37in	3.47in
1.6t 3527lbs	7.1mm	6.7mm	105.3mm	108.4mm
	0.27in	0.26in	4.14in	4.26in
3.2t 7054lbs	9.0mm	8.5mm	135.3mm	139.3mm
	0.35in	0.33in	5.32in	5.48in
6.3t 13889lbs	9.0mm	8.5mm	135.3mm	139.3mm
	0.35in	0.33in	5.32in	5.48in
9t 19841lbs	9.0mm	8.5mm	135.3mm	139.3mm
	0.35in	0.33in	5.32in	5.48in

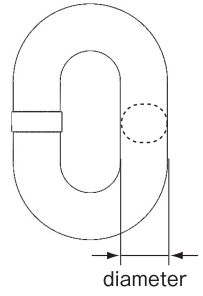
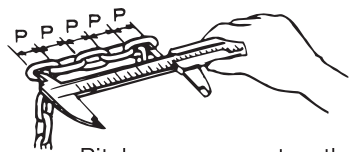

Figure 49

Wear of the diameter is not to exceed 5% of the dimension value indicated above. 5-link pitch must not be elongated by 3% or more of the dimension value indicated above.



Pitch measurement method

Figure 50

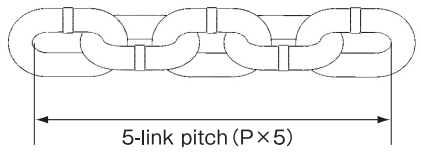

5-link pitch

Figure 51

※Model YAⅢ uses five different parts: No. 238 feed gear, No. 287 spring for floating mechanism, No. 288 feed handle, No. 292 name plate, and No. 203 Hex. socket head cap screw set.

Lubrication and greasing of various parts

Load chain

- First, use cleaning solution to remove dust and dirt from the load chain.
- Apply NLGI No. 00 grease.
- Depending on the frequency of use and other conditions, increase the frequency of grease application to the load chain during daily inspections.

Gears and other parts

- First, use cleaning solution to remove any dust and dirt from the old grease coating of the gears.
- Apply NLGI No. 1 grease evenly to the gear sections.
- Apply grease to the pawls and rotating parts of the lever, as well as the rotating parts of the load sheave and side plate.

7. Disassembly and Assembly Adjustment

7.1 Tools and Equipment/Consumables used for Disassembly/Assembly

Prepare the following tools and supplies :

1. Wrench
2. Phillips screwdriver
3. Nippers
4. Pliers
5. Hexagonal wrench
6. Radio pliers
7. Snap ring pliers
8. Plastic hammer
9. Brush
10. Grease (NLGI. No. 1)
11. Oil (NLGI. No. 00)
12. Waste cloth
13. Cylindrical or square pipe-shaped object (Height: approx. 100 mm; hole diameter should be enough to fit the pinion shaft)

Part No. and parts used

NO.2	Hexagon socket head cap screws : M4, 5, 6, 8, 10
NO.8	Chain stop bolt sets : M6, 8, 10, 12
NO.13	Hex.nuts : M8, 10
NO.21	Hex. castle nuts : M10/12
NO.36	Hex.nuts : M8
NO.103	Hex. socket head cap screw sets : M6

※Apply gear grease (NLGI. No. 1) and load chain oil (NLGI. No. 00) .

※Use the following tools to disassemble and reassemble the hoist.
Be sure to work carefully.

1. Wrench

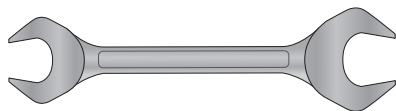

2. Phillips screwdriver

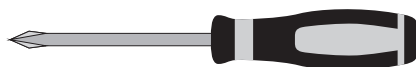

3. Nippers

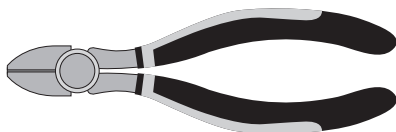

4. Pliers

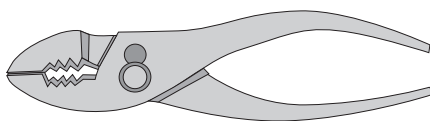

5. Hexagonal wrench

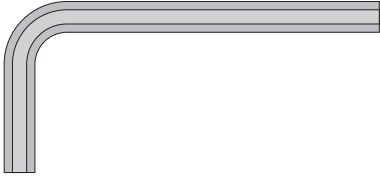

6. Radio pliers

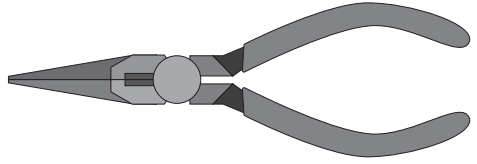

7. Snap ring pliers

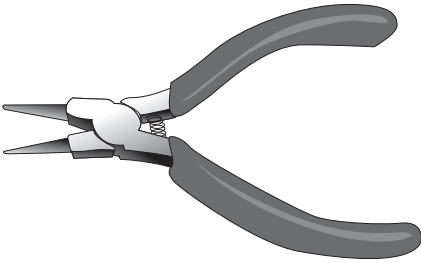

8. Plastic hammer

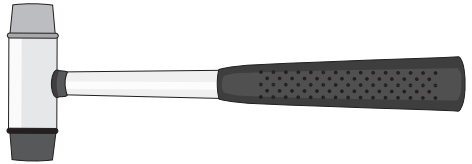

9. Brush

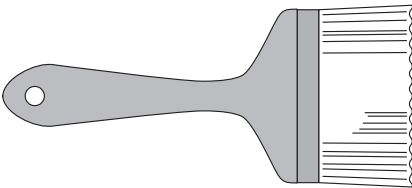

7.2 Disassembly of Model YA

※Refer to the breakdown schematics for detailed part numbers.

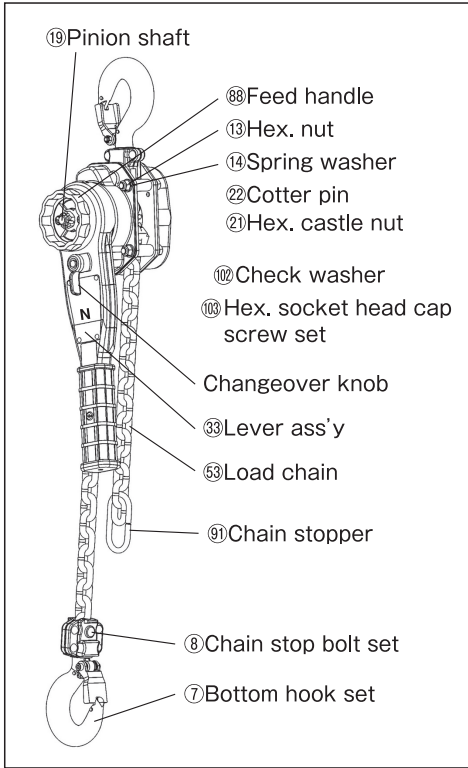

Disassembly of the main unit, lever, and chain

- ① Remove chain stop bolt set ⑧ on the load side of the load chain, then remove bottom hook ass'y ⑦. Remove chain stopper ⑨① on the no-load side.
- ② Set changeover knob to position N (revolving), perform free chaining operation and rotate the feed handle ⑧⑧ to remove the chain.
- ③ Remove cotter pin ②②, hex. castle nut ②① and check washer ⑩⑩ from pinion shaft ①⑨.
- ④ Remove hex. socket head cap screw sets ⑩⑩ securing the feed handle ⑧⑧, and disengage the handle.
- ⑤ Remove hex. nut ⑬⑬ and spring washer ⑭⑭ holding lever ass'y ③③ in place.
- ⑥ While turning feed gear ⑧⑧, disengage lever set from the main unit.

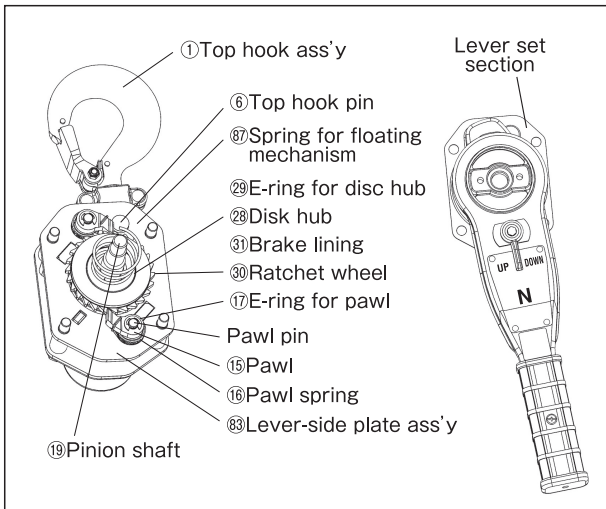

Disassembling the hoist body

- ① Remove spring for floating mechanism ⑧⑦.
- ② Pull out the top hook pin ⑥ and remove the top hook ass'y ①.
- ③ Remove E-ring for disc hubs ②⑨ attached to pinion shaft ①⑨.
- ④ Remove brake parts. (Remove in this order: brake linings ③①; ratchet wheel ③①; brake linings ③①; disk hub ②⑧)
- ⑤ Remove in this order: E-ring for pawl ①⑦ attached to the pawl pin; pawl ①⑤; pawl spring ①⑥.
- ⑥ Remove lever-side plate ass'y ⑧③.

- 7 Remove chain guide ass'y 26 and chain stripper 27.
- ※ Prepare an assembly mounting (if possible)
If a mounting is unavailable, substitute with an appropriate surface.
The assembly mounting should be a pipe-shaped cylinder, with sufficient length to house pinion shaft 19 and capable of supporting load sheave 25.
- 8 Turn the main unit over and place it on the assembly mounting.
Remove hex. nuts 13 and spring washer 14 securing gear cover ass'y 18, and disengage the gear cover.

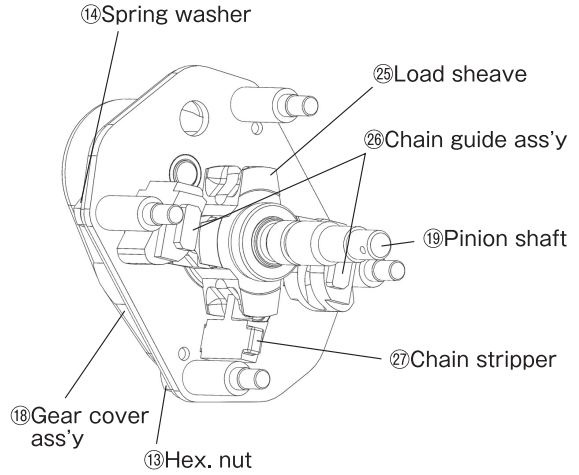

- 9 Remove 2nd and 3rd gear ass'y 23
- 10 Remove Pinion shaft 19
- 11 Remove washer for pinion shaft 20
- 12 Remove Load gear 24
- 13 Remove gear-side plate ass'y 82
- 14 Remove Load sheave 25 from assembly mounting

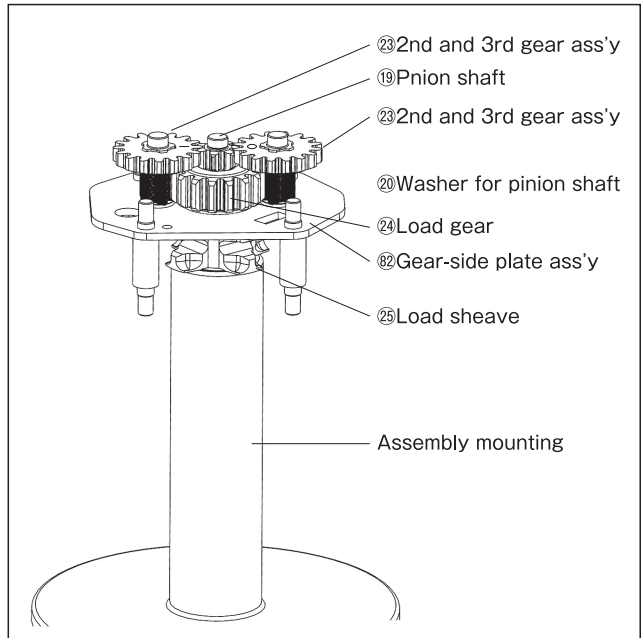

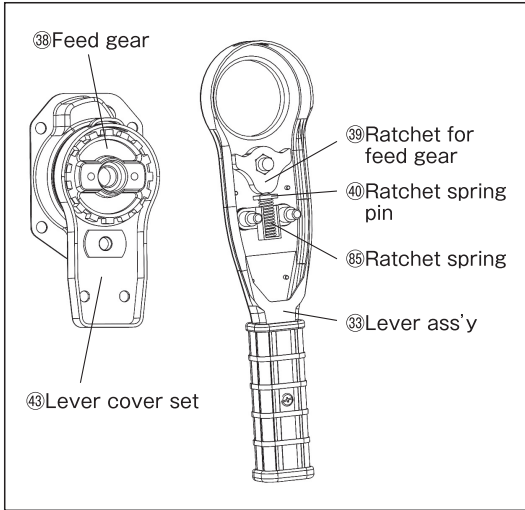

Disassembling the lever section

- 1 Lever ass'y 33 and lever cover set 43 can be disassembled into two parts by removing hex nuts 36 and spring washer 37 holding the two sets together.
- 2 Remove ratchet for feed gear 39, ratchet spring pin 40 and ratchet spring 35 from the lever ass'y.
- 3 Disengage feed gear 38 from the lever cover set.

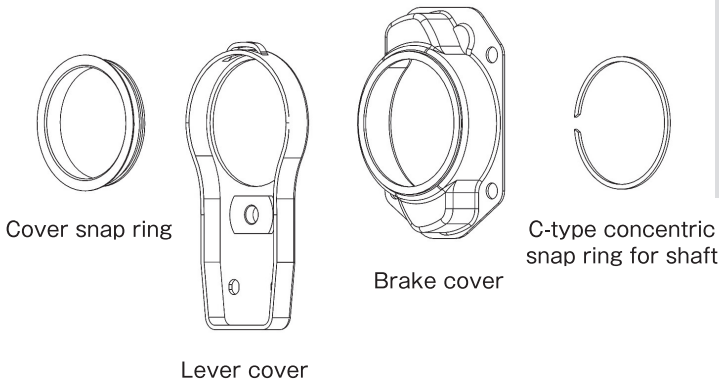

- 4 Remove the C-type concentric snap ring from the shaft retaining the lever cover set, and disassemble cover set.

※This completes the disassembly of the lever. Then, remove (clean) any dirt, dust, or grease from the disassembled parts for inspection and re-assembly. Inspect respective parts in accordance with the inspection standards. Replace any damaged or deteriorated parts with new parts. In case many parts are damaged or deteriorated, the purchase of new levers is recommended to enhance safety.

7.3 Assembly and Adjustment

※Refer to the breakdown schematics for detailed part numbers.

Start re-assembly of the Model YA lever hoist. (Assuming all parts are intact and in normal condition)

1. Prepare lever ass'y ③③.

※The grip and assembly screws to be pre-assembled.

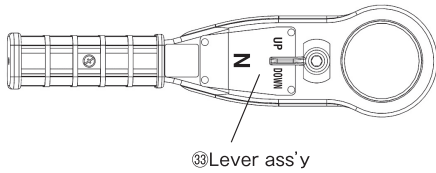

2. Assemble the lever ass'y.

Install ratchet for feed gear ③⑨, ratchet spring pin ④①, and ratchet spring ④⑤ to the lever ass'y.

※When installing ratchet for feed gear, the changeover knob must be set to the N (free chaining) position.

※Apply grease to parts ③⑨, ④① and ④⑤ with a brush or similar tool.

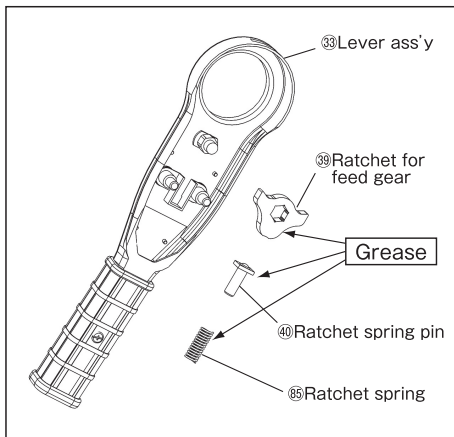

3. Assemble lever cover set ④③.

※Be sure to apply grease to the rotating parts.

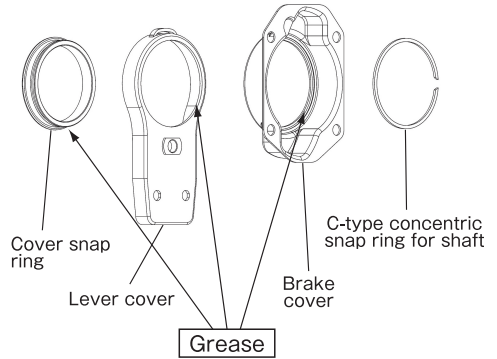

4. Assemble lever ass'y and lever cover set.

Apply grease to the gear portion of feed gear ③⑧. Then, place the feed gear on lever ass'y ③③, cover it with the lever cover set, and secure with spring washer ③⑦ and hex. nut ③⑥.

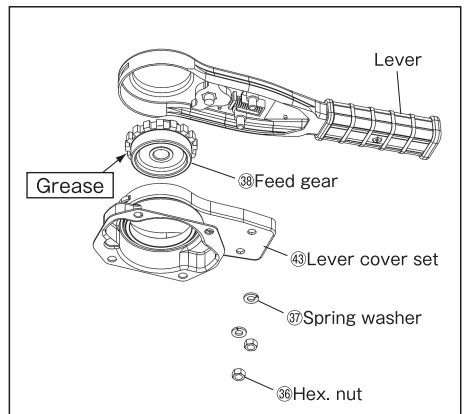

5. This completes the assembly of the lever ass'y and lever cover set.

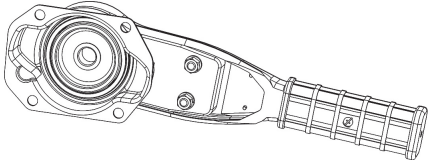

6. Prepare assembly mounting (if possible)

- ※In case mounting is unavailable, substitute with an appropriate surface.
- ※Assembly mounting should be a pipe-shaped cylinder, with sufficient length to house the pinion shaft and capable of supporting load sheave 25.

First, apply grease to the rotating portion of load sheave 25 and place it on the assembly mounting.

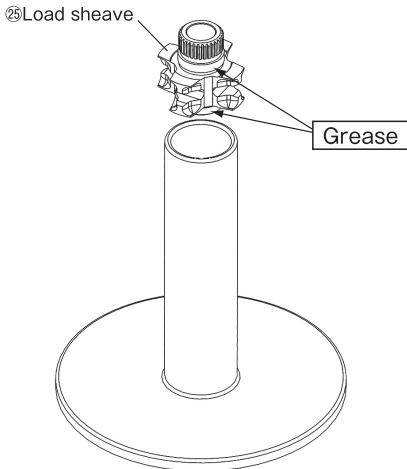

7. Install gear-side plate ass'y 82 on the mounted load sheave.

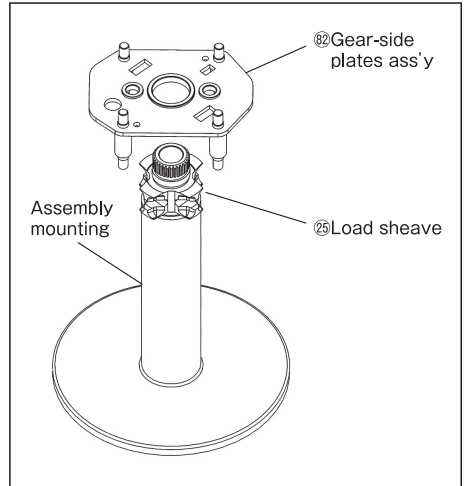

8. Unit with the load sheave and the gear-side plate ass'y installed

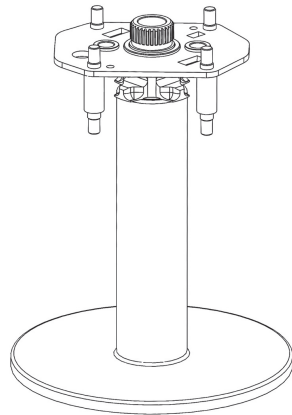

9. Install load gear ⑳ on the load sheave with the recessed section facing upward.

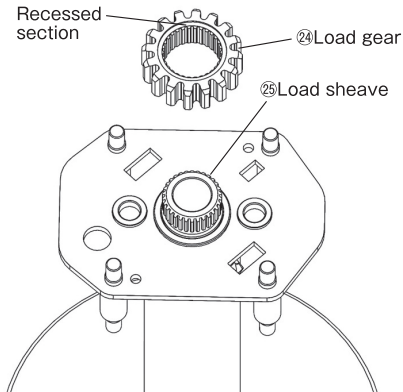

10. Install washer for pinion shaft ㉑ (flat part to face the load gear side) on top of the installed load gear ㉒.

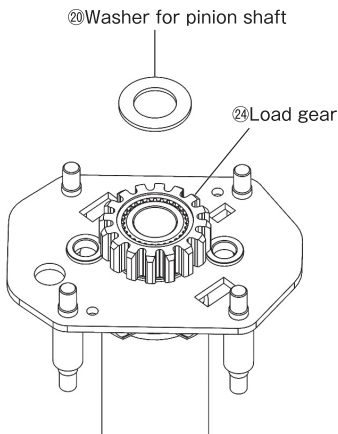

11. Apply grease to the area indicated by the arrow and assemble pinion shaft ㉓.

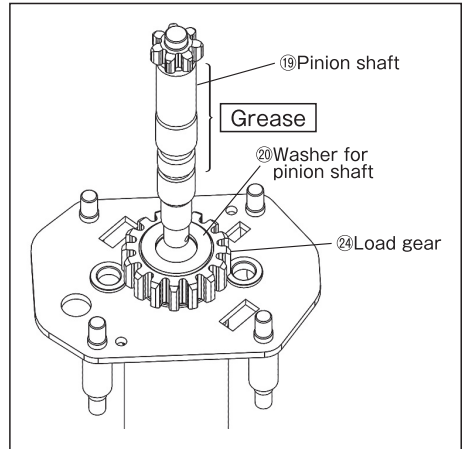

12. Prepare the 2nd and 3rd gear ass'y ㉔, apply grease to the section that contacts the metal part of the side plate. The gear section is provided with markings. Install gears with the marks facing each other.

※After installing the gears, confirm smooth rotation by turning them.

Gear combination		
0.8, 1t	○	
1.6t	○	
3.2t, 6.3t, 9t	0	↑

※Misalignment of marks may result in preventing the gears from rotating or cause other problems.

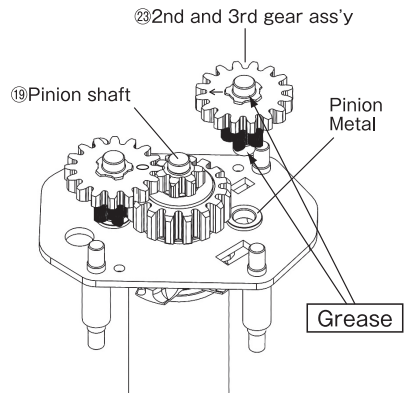

13. This completes the installation of second and third gears.

Apply grease to the load gear, pinion shaft, second and third gears, and all of the rotating parts.

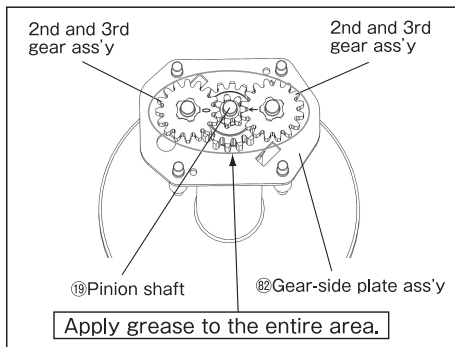

14. Cover the gear section with gear cover ass'y ⑱.

※Align the top hook pin hole side, convex part, and screw hole positions.

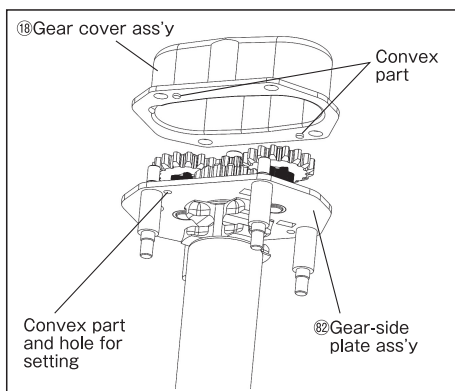
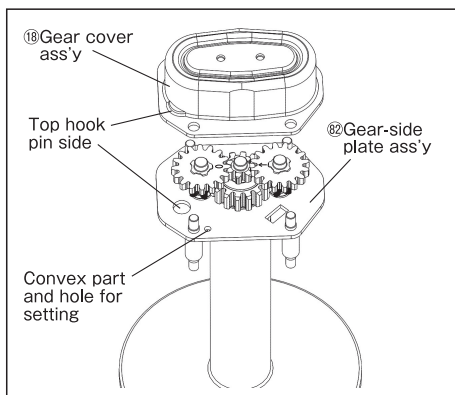

15. Secure the gear cover ass'y and gear-side plate ass'y with spring washer ⑭ and hex. nut ⑬.

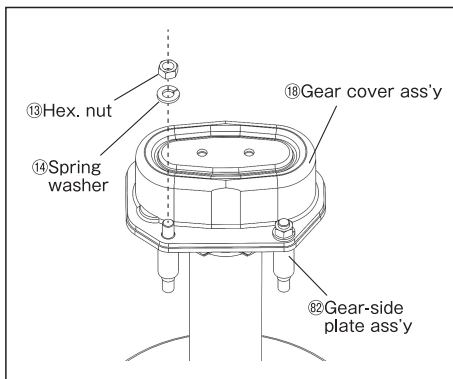

16. Remove the parts installed so far from the assembly mounting and place them on the work table.

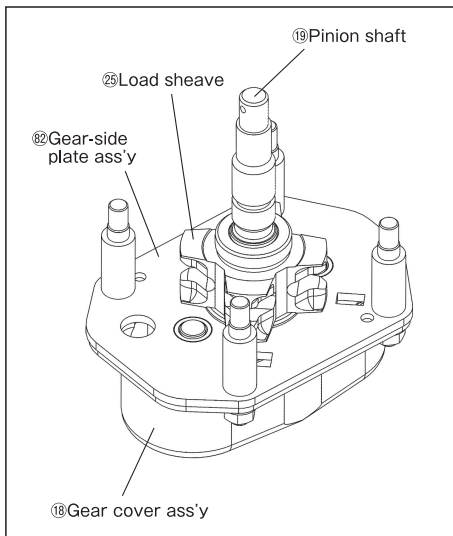

17. Next, install chain guide ass'y ⑳ and chain stripper ㉗.

※Be sure to align the parts correctly for assembly. Install the chain stripper with the higher end facing the stopper and the lower end facing toward the bottom hook.

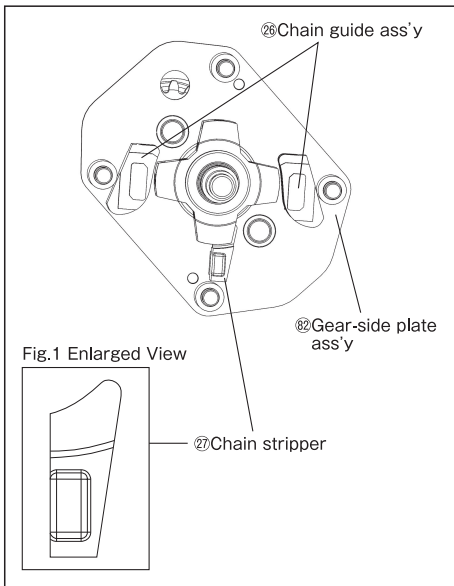

18. Install the lever-side plate ass'y.

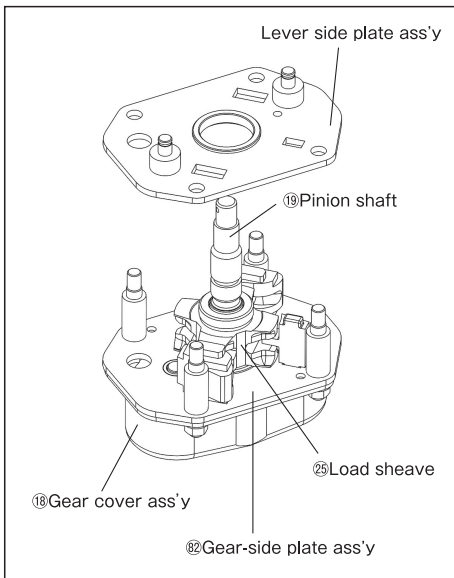

19. Condition of the hoist with the gear side and lever side installed

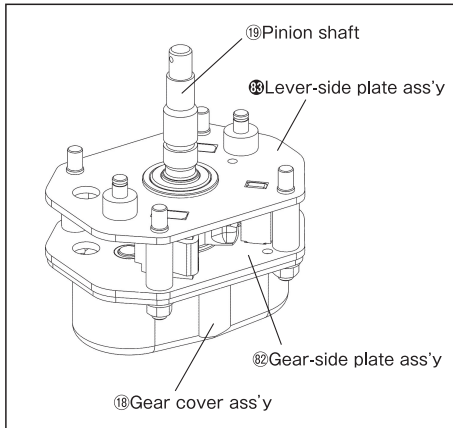

20. Install pawl spring ⑳, pawl ㉕ and E-ring for pawl ㉖ to the lever-side plate.

※Apply a small amount of grease to the pin before attaching the pawl.

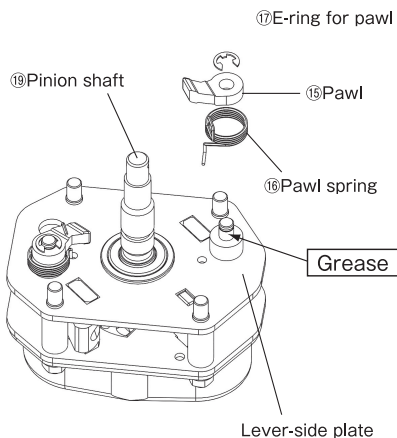

21. Install disc hub 28 onto pinion shaft 19.

Since the shaft is threaded, turn the disk hub by hand and tighten until it does not move.

※Open the two pawls sideways and attach so that they do not touch each other.

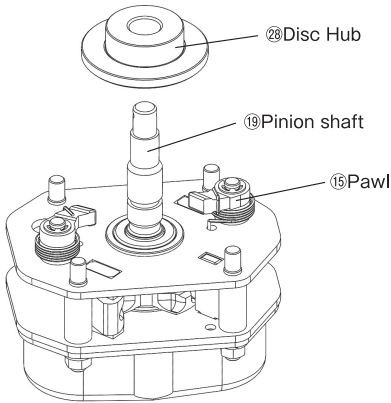

22. Condition of the hoist with the disk hub installed onto the pinion shaft

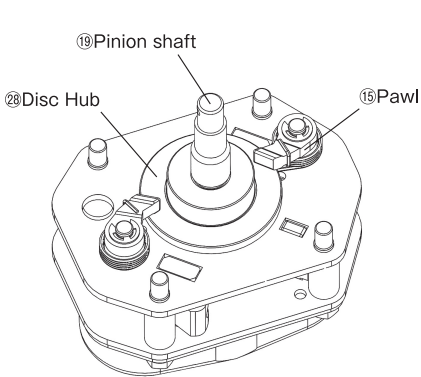

23. Install ratchet wheel 30 and brake linings 31 to disc hub 28.

※Be sure to attach the ratchet wheel in the correct orientation.

※If the direction is reversed, the brakes will not work and the pawls will not engage with the ratchet wheel.

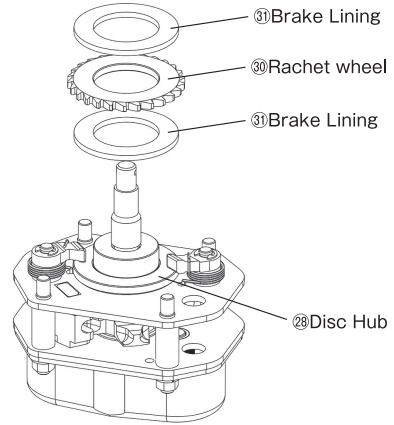

24. This completes the installation of the brakes

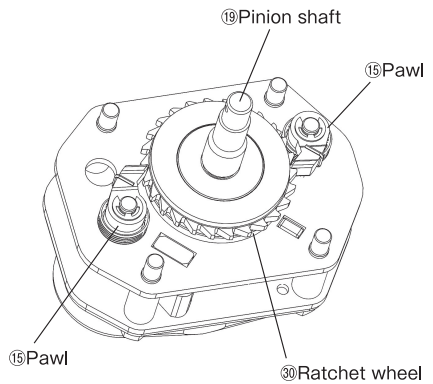

25. Install the E-ring for disc hub onto the pinion shaft.

※Install E-ring for disc hub securely onto the shaft as far as it will go (with the curved part facing the disc hub).

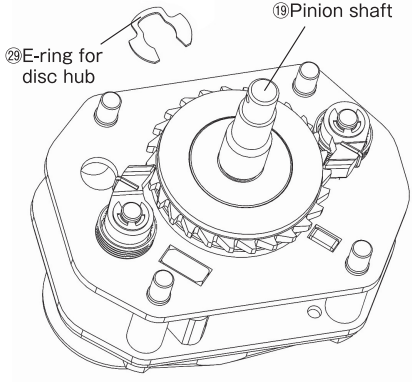

26. With E-ring for disc hub installed

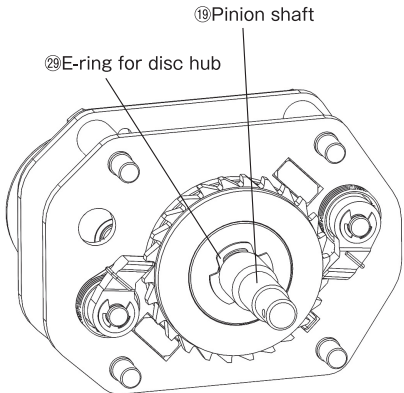

27. Install top hook ass'y ❶.

Align top hook hole with the hook hole on the side plate, and secure hook with ❷ top hook pin.

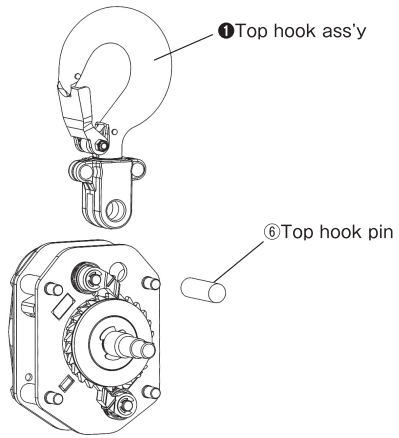

28. With top hook ass'y installed

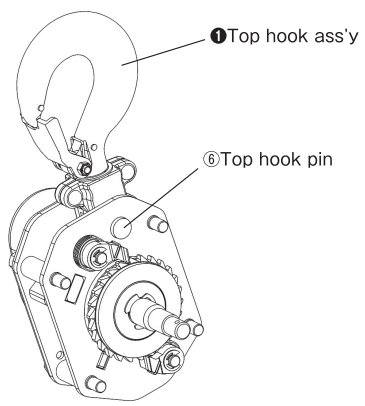

29. Install spring for floating mechanism ⑧7 onto the pinion shaft.

※The end with the smaller spring diameter should face the disk hub.

※The diameter of the spring is the same on both ends in the case of Model YAⅢ.

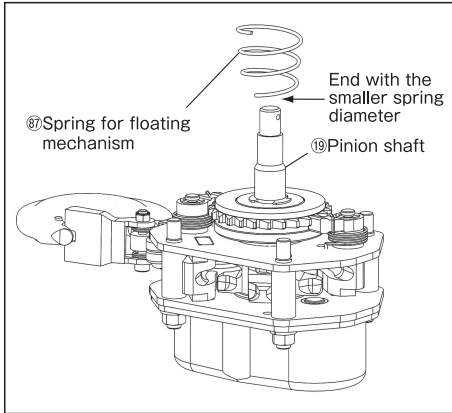

31. Secure the body part attached with the top hook and lever section with spring washer ①4 and hex. nut ①3.

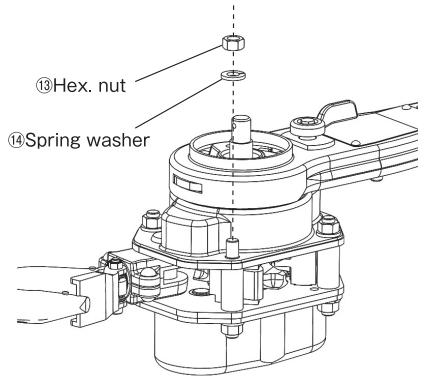

30. Attach the lever part to the body part with the top hook.

Align the top hook hole on the lever cover with the screw hole. Both the feed gear and pinion shaft are threaded. Attach feed gear to the shaft by rotating the gear by hand.

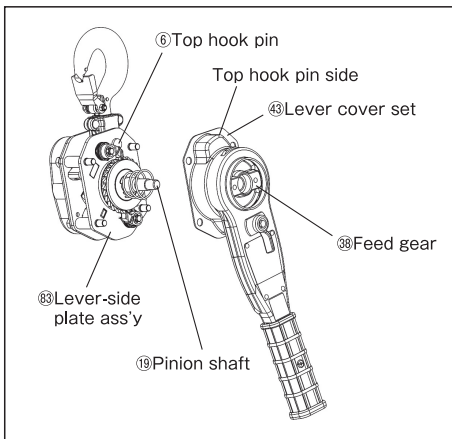

32. Next, install feed handle ⑧8.

Insert handle onto the pinion shaft and align with the screw hole on the feed gear.

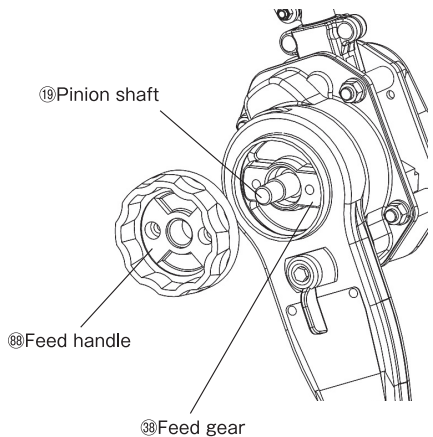

33. Secure feed handle using hex. socket head cap screw sets ⑩.

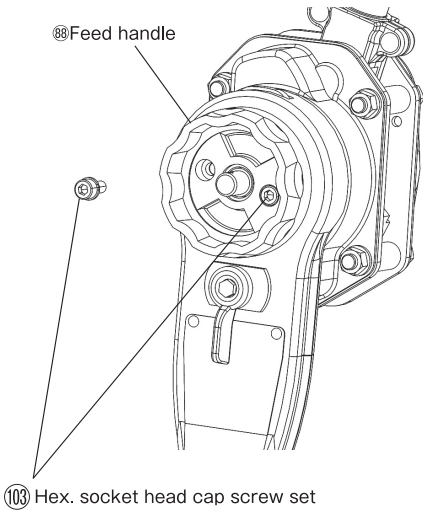

34. Pass check washer ⑩ through the pinion shaft and attach to the feed handle.

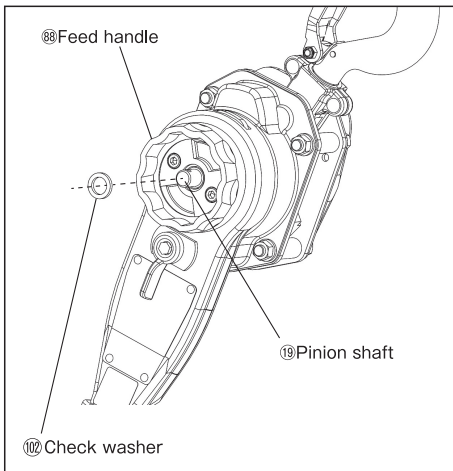

35. Next, screw hex. castle nut ⑪ onto the pinion shaft.

※Screw the nut onto the pinion shaft by hand.

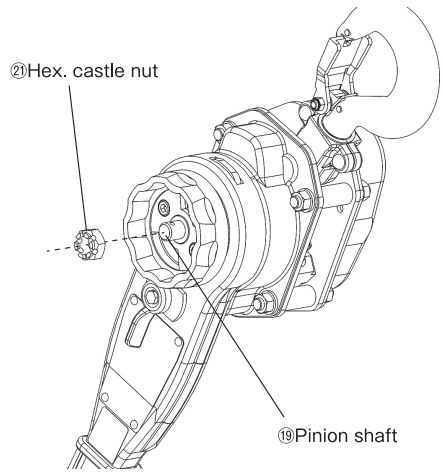

36. Pinion shaft with hand-tightened hex. castle nut

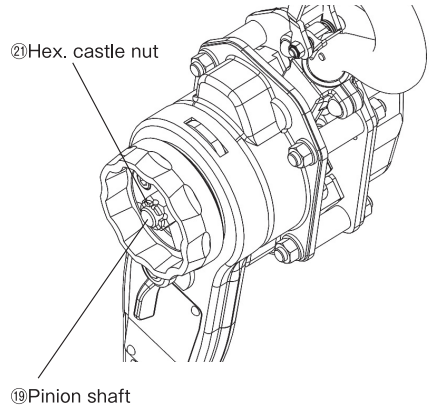

37. Viewing the assembled lever from above, orient the feed handle to the right and the gear side to the left. In this state, install the load chain.

Set changeover knob to the free chaining (N) position. Place the load chain in the load sheave 25 with the vertical link (welding side) facing upward, and feed the load chain to the no-load side while turning the feed handle 88 to the right by hand.

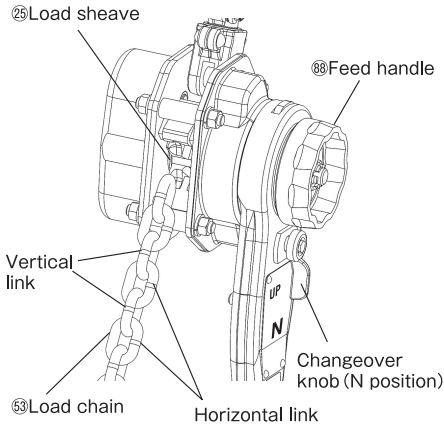

38. When load chain is installed onto the main unit

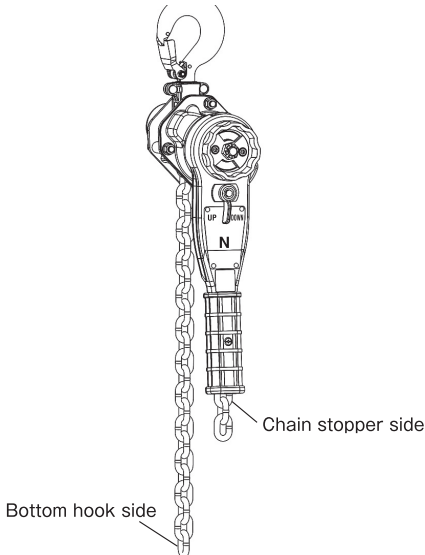

39. Attach chain stopper 91 to the second link of the load chain on the no-load side.

※When top hook and lever section are correctly aligned, the left side becomes is the load side (lifting side) and the right side is the no-load side (lowering side) as viewed from the feed handle side.

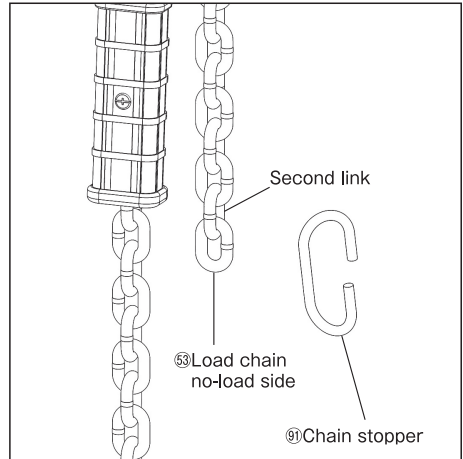

40. Install bottom hook ass'y 7 onto the load side of the load chain.

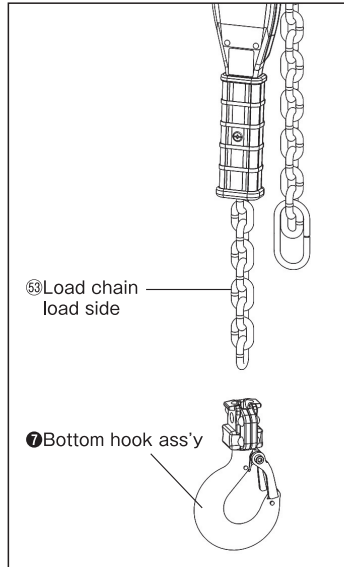

41. Install chain stop bolt set ⑧, orienting the welded side of the second link of the load chain toward the nut.

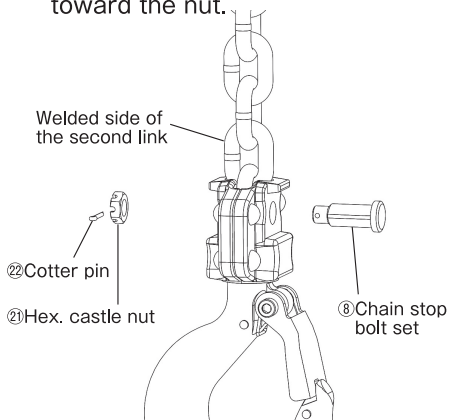

42. Hook the top and bottom hooks of the lever onto the fixing bracket, set the changeover knob to the lifting position, then tighten hex. castle nut ① until it does not turn by hand. Next, turn the feed handle lift-ward by hand until it stops turning.

※Apply load to the lever.

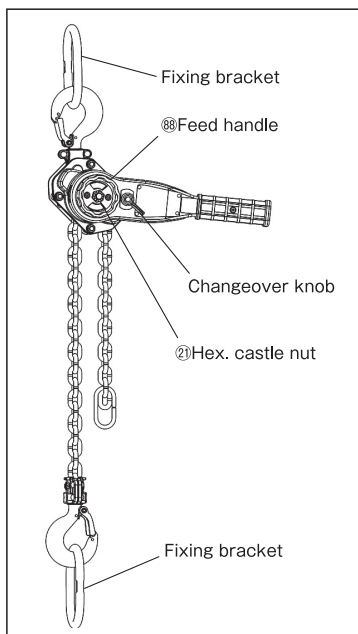

43. Confirm hole position of the hex. castle nut and the cotter pin hole of the pinion shaft. Even if the hole positions are aligned, loosen by one groove. If the holes are half aligned or not aligned at all, loosen the nut by two grooves. Next, insert the cotter pin into the adjusted hole and secure the nut with the cotter pin to prevent it from loosening.

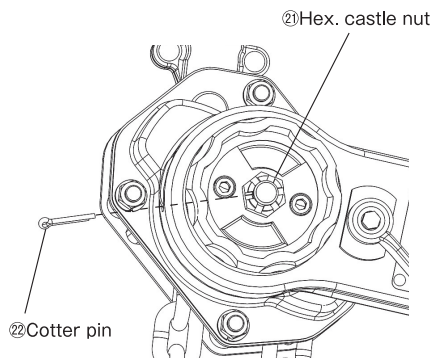

When the hole position is aligned

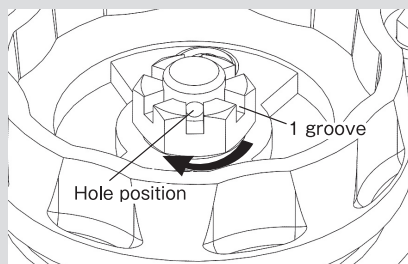

When the hole position is not aligned

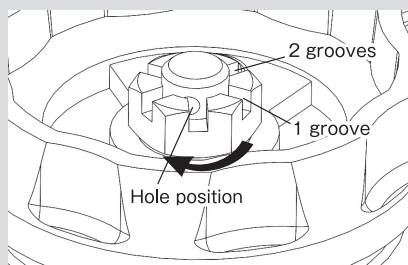

44. Condition with cotter pin ② secured.

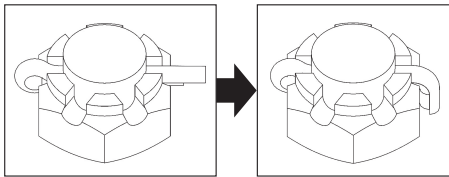
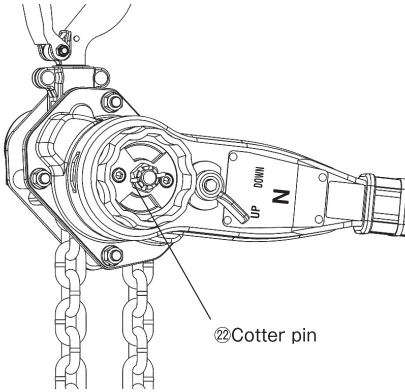

Insert and bend cotter pin ②.

45. Set changeover knob to lowering position and move handle to loosen load chain ⑤.
Apply oil to the load chain.

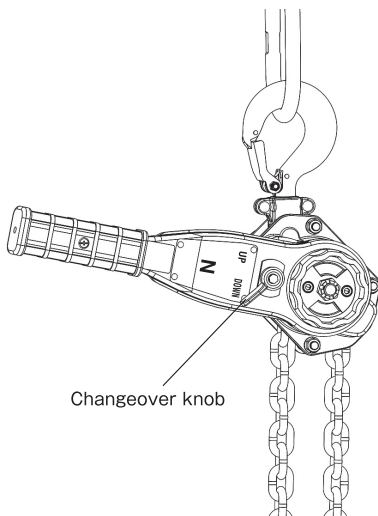

46. This completes the assembly process.
After completing the assembly, be sure to perform an operation check before use.

※Points for operation check

- ① Check overall appearance for anomalies.
Are there any leftover parts?
- ② Does the hoist make any abnormal noises when lifted/lowered under no-load condition?
Can the engaging of the pawl be audibly confirmed when lifting?
Is the manual power required to turn the lever not too heavy?
- ③ After confirming normal operation under no-load conditions, test operation upon applying a load.
Is there any slippage of the brake?

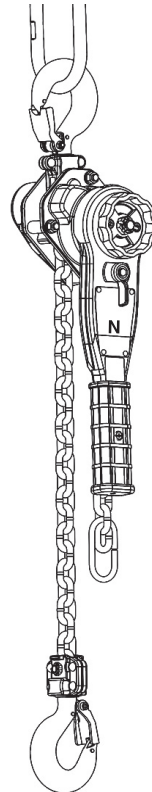

7.4 Is this a malfunction!? First check for (commonly found assembly errors)

· Check again according to the instructions below before calling for repairs:

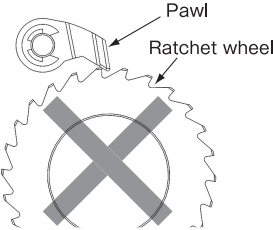
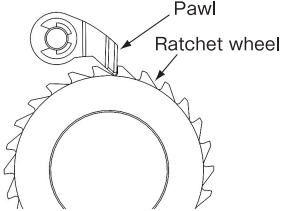
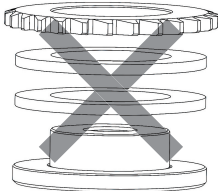
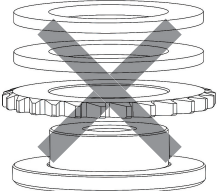
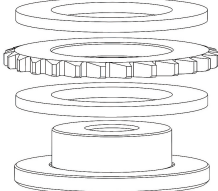
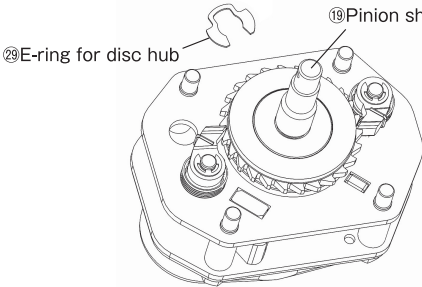
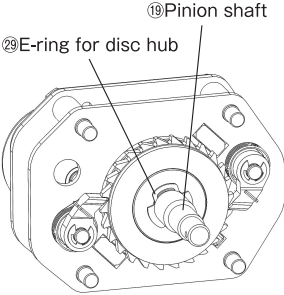
When in this situation:	The cause and target of inspection is:	How to fix:
<p>①Lever does not move either up or down. There is no audible pawl engaging sound.</p>	<p>Ratchet wheel in the brake section is not assembled correctly. Ratchet wheel is assembled backwards and is not engaged with the pawl.</p> 	<p>Reassemble ratchet wheel correctly. Make sure the pawl and the ratchet wheel are engaged, and also check for the clicking sound when the ratchet wheel is turned.</p> 
<p>②Lever does not move either up or down. There is no audible pawl engaging sound.</p>	<p>The brake part is assembled correctly, but there is no sound of the pawl and ratchet wheel engaging. Check the brake section, pawl and pawl spring for dirt, corrosion, or spring failure.</p>	<p>Disassemble, clean and lubricate the brake, pawl, and pawl spring parts. Replace pawl spring and check the spring force.</p>
<p>③Lever does not move either up or down. There is no clicking sound of the pawl engaging.</p> 	<p>Ratchet wheel is not assembled correctly. Pawl does not make proper contact with the wheel. Pawl spring is damaged.</p> 	<p>Assemble correctly so that the pawl engages the ratchet wheel. Confirm the clicking sound of ratchet wheel meshing with the pawl before use.</p> 
<p>④Lever does not move either up or down.</p> 	<p>E-ring for disc hub is not attached. When E-ring for disc hub is not attached, a gap will be created in the brake section, interfering with the lift-lowering operation.</p>	<p>Install E-ring for disc hub correctly.</p> 

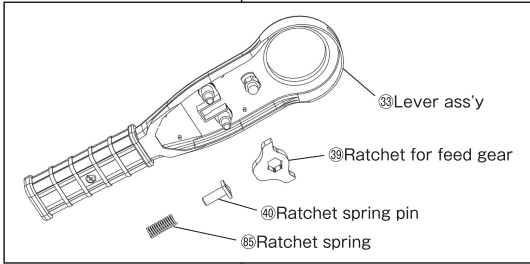
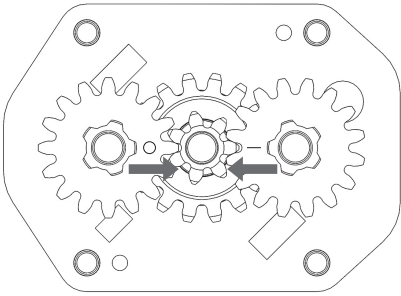
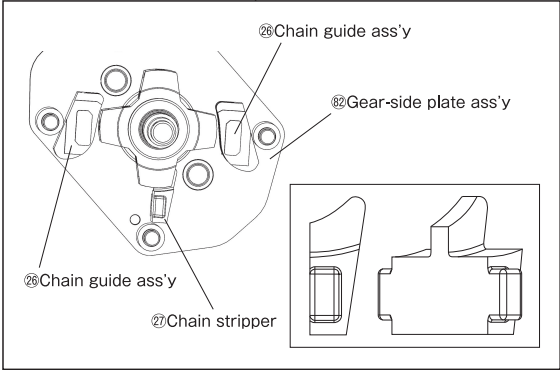
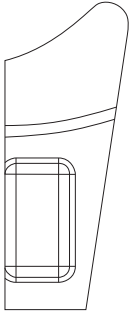
When in this situation:	The cause and target of inspection is:	How to fix:												
<p>⑤Lever does not move either up or down. There is no audible pawl engaging sound.</p> 	<p>When attaching feed gear pawl to the lever, the pawl may have been attached without checking the setting of the changeover knob to position N.</p>	<p>Check that the changeover knob is set to N, and then install the feed gear pawl. After installing the lever, align feed gear pawl to UP and DN positions, and check if the feed gear pawl and feed gear engage each other with audible clicking sounds.</p>												
<p>⑥Lever does not move. Lever rotation is heavy.</p> 	<p>Incorrectly assembled second and third gears.</p>	<p>Marks are engraved on the 2nd and 3rd gears. Install them so O and I are facing each other. After installing, rotate gears to make sure they are not stuck.</p> <table border="1" data-bbox="714 730 1014 855"> <thead> <tr> <th colspan="3">Gear combination</th> </tr> </thead> <tbody> <tr> <td>0.8, 1t</td> <td>O</td> <td>I</td> </tr> <tr> <td>1.6t</td> <td>O</td> <td>I</td> </tr> <tr> <td>3.2t, 6.3t, 9t</td> <td>O</td> <td>↑</td> </tr> </tbody> </table>	Gear combination			0.8, 1t	O	I	1.6t	O	I	3.2t, 6.3t, 9t	O	↑
Gear combination														
0.8, 1t	O	I												
1.6t	O	I												
3.2t, 6.3t, 9t	O	↑												
<p>⑦Chain does not move smoothly.</p> 	<p>Chain stripper is not oriented correctly.</p>	<p>Make sure the chain stripper is oriented correctly.</p> 												

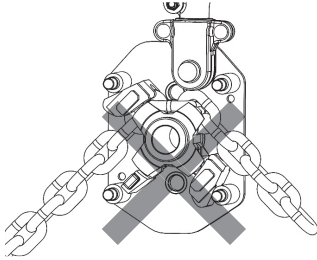
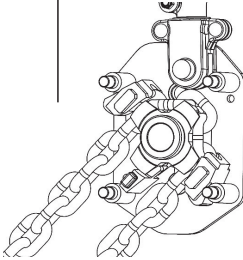
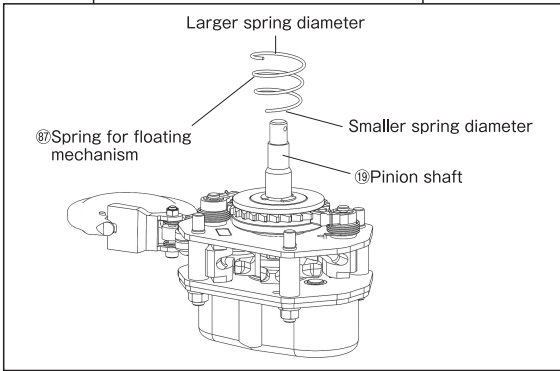
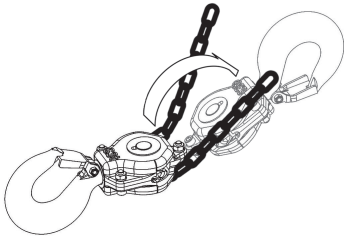
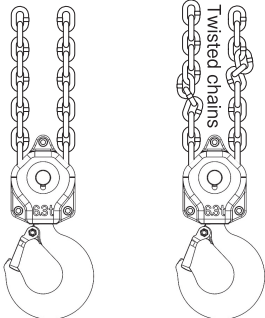
When in this situation:	The cause and target of inspection is:	How to fix:
<p>⑧Chain does not move smoothly.</p> 	<p>Chain is not threaded in the correct position, and the meshing between the chain and the load sheave is not sufficient.</p>	<p>Reassemble the chain in the correct position and check the chain engagement rise.</p> 
<p>⑨Chain does not move smoothly.</p>	<p>Incorrect assembly of the auto-rotating spring. The end of the spring with the larger diameter is facing the disk hub side.</p> 	<p>Reassemble correctly. Assemble so that the end of the spring with the smaller diameter is positioned on the disk hub side and the end with the larger diameter is on the feed handle side.</p>
<p>⑩Bottom hooks on two-hoist lifting type equipment does not lift fully to the end (touching the body).</p> 	<p>Bottom hook is reversed and the chain is twisted.</p> 	<p>Restore reversed bottom hook and check if the chain is twisted. Then confirm whether the bottom hook rises fully until it touches the main unit.</p> <div style="border: 2px solid black; padding: 5px; text-align: center;"> <p>Do not operate unit in this condition!</p> </div> <p>Twisted chain due to reversed hook</p>

When in this situation:	The cause and target of inspection is:	How to fix:
<p>⑪ Unable to perform lowering operation</p>	<p>Hex. castle nut is left tightened to the end. Impact load has been applied. (Unable to perform lowering operation due to biting)</p>	<p>Loosen Hex. castle nut by one or two holes and readjust. In case of biting, lift load once and release brake by setting lever to lowering.</p>

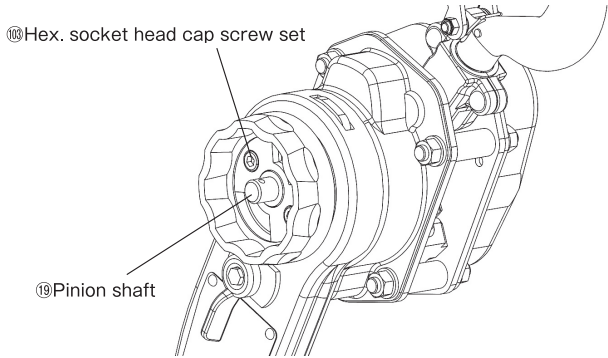

If hole position is just right, loosen by one groove.

If nut is positioned over the hole position, loosen nut by 2 grooves.

When the hole position is aligned

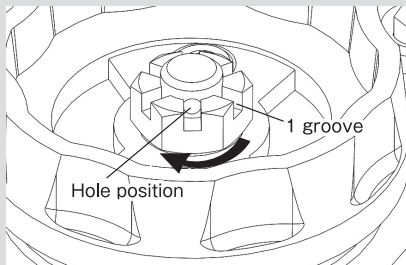

When the hole position is not aligned

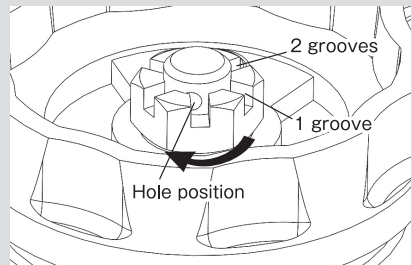

<p>⑫ Load slips and skids while descending.</p>	<p>Foreign matter is lodged in the brake section. Brake section is not assembled correctly. Brake is damaged or worn.</p>	<p>Remove foreign matter and clean the brake section. Reassemble correctly. Replace with a new part.</p>
<p>⑬ The lever cannot be lowered after it has been used once.</p>	<p>Brake has become engaged. ※The brake section is configured similarly to a bolt and nut mechanism. Biting is similar to excessively tightened nuts. When disassembling the lever, it was removed without lowering (release the brake).</p>	<p>Apply load to the lever and provide some extra force to the lowering motion to release the brake. Clean the brake section.</p>
<p>⑭ Load chain does not move freely during free chaining operation.</p>	<p>Load chain was pulled too hard during free chaining operation, and the brakes engaged.</p>	<p>Pull slowly on the load chain.</p>

Inspection records

Model		Date of inspection	
Tonnage		Name of qualified person (Name of inspector)	
Production No.			
Lift			

Inspection Part
(Part No., Part Name)

Inspection contents

Judgment Remarks

		Inspection contents	Judgment	Remarks
1		Top hook ass'y		
		Check for openings in hook, twists, damage, etc.		
		Between punches		
		Hook thickness, vertical		
		Hook thickness, horizontal		
		Hole diameter of top hook pin		
	2	Safety latch set	Whether the hook is engaged, damaged, deformed, etc.	
6		Top hook pin	Inspect for pin diameter wear.	
7		Bottom hook ass'y		
		Check for openings in hook, twists, damage, etc.		
		Between punches		
		Hook thickness, vertical		
		Hook thickness, horizontal		
		Hole diameter of chain stop bolt set		
	2	Safety latch set	Whether the hook is engaged, damaged, deformed, etc.	
	8	Chain stop bolt set	Check the bolt diameter for wear, damage, deformation, etc.	
13		Hex. nut	Inspect for damage, wear, deformation, etc.	
14		Spring washer	Inspect for damage, wear, deformation, etc.	
18		Gear cover ass'y	Inspect for wear with bumps identifiable by hand and other damage.	
19		Pinion shaft	Inspect for chipped gear teeth and other damage	
20		Washer for pinion shaft	Inspect for damage, wear, deformation, etc.	
21		Hex. castle nut	Inspect for damage, wear, deformation, etc.	
22		Cotter Pin	Inspect for damage, wear, deformation, etc.	
23		2nd and 3rd gear ass'y	Inspect for chipped gear teeth and other damage	
24		Load gear	Inspect for chipped gear teeth and other damage	
25		Load sheave	Inspect for engagement with the chain, damage, deformation, etc.	
26		Chain guide ass'y	Inspect for proper operation of the changeover knob	

Inspection Part
(Part No., Part Name)

Inspection contents

Judgment Remarks

27	Chain stripper	Inspect for cracks in the rubber handle, deformation, etc.		
28	Disk hub	Inspect for damage, wear, deformation, etc.		
29	E-ring for disc hub	Inspect for damage, wear, deformation, etc.		
30	Ratchet wheel	Inspect for chipped gear teeth and other damage		
31	Brake lining	Inspect for chipped pawls, wear, etc.		
33	Lever ass'y	Inspect for damage, wear, deformation, etc.		
34	Lever grip	Inspect for damage, wear, deformation, etc.		
35	Bracket screw	Inspect for wear and deformation of the pin hole diameter in the respective parts		
92	Name plate	Inspect for wear and deformation of the pin hole diameter in the respective parts		
36	Hex. nut	Inspect for damage, wear, deformation, etc.		
37	Spring washer	Inspect for damage, wear, deformation, etc.		
38	Feed gear	Inspect for wear with bumps identifiable by hand and other damage.		
39	Ratchet for feed gear	Inspect for damage, wear, deformation, etc.		
40	Ratchet spring pin	Inspect for openings in the snap ring and damage, etc.		
43	Lever cover set	Inspect for damage, wear, deformation, etc.		
82	Gear-side plate ass'y	Inspect for damage, wear, deformation, etc.		
83	Lever-side plate ass'y	Inspect for damage, wear, deformation, etc.		
15	Pawl	Inspect for damage, wear, deformation, etc.		
16	Pawl spring	Inspect for damage, wear, deformation, etc.		
17	E-ring for pawl	Inspect for damage, wear, deformation, etc.		
85	Ratchet spring	Inspect for damage, wear, deformation, etc.		
87	Spring for floating mechanism	Inspect for damage, wear, deformation, etc.		
88	Feed handle	Inspect for damage, wear, deformation, etc.		
91	Chain stopper	Inspect for chipped gear teeth and other damage		
102	Check washer	Inspect for openings in the snap ring and damage, etc.		
103	Hex. socket head cap screw set	Inspect for chipped gear teeth and other damage		
110	Tag	Inspect for chipped gear teeth and other damage		
53	Load chain	Inspect for wear, damage, deformation, etc.		

Judgment : ○ (Good) , × (Replacement)

※Perform the inspections and tests indicated above. Be sure to maintain records of the inspections.

※Be sure to replace any parts that are found to be even slightly unsafe with new parts.

※Please inspect based on ASME B30.21.

Breakdown Schematics and Parts Names : Models YA-80, 100, 160, 320, 630, 900

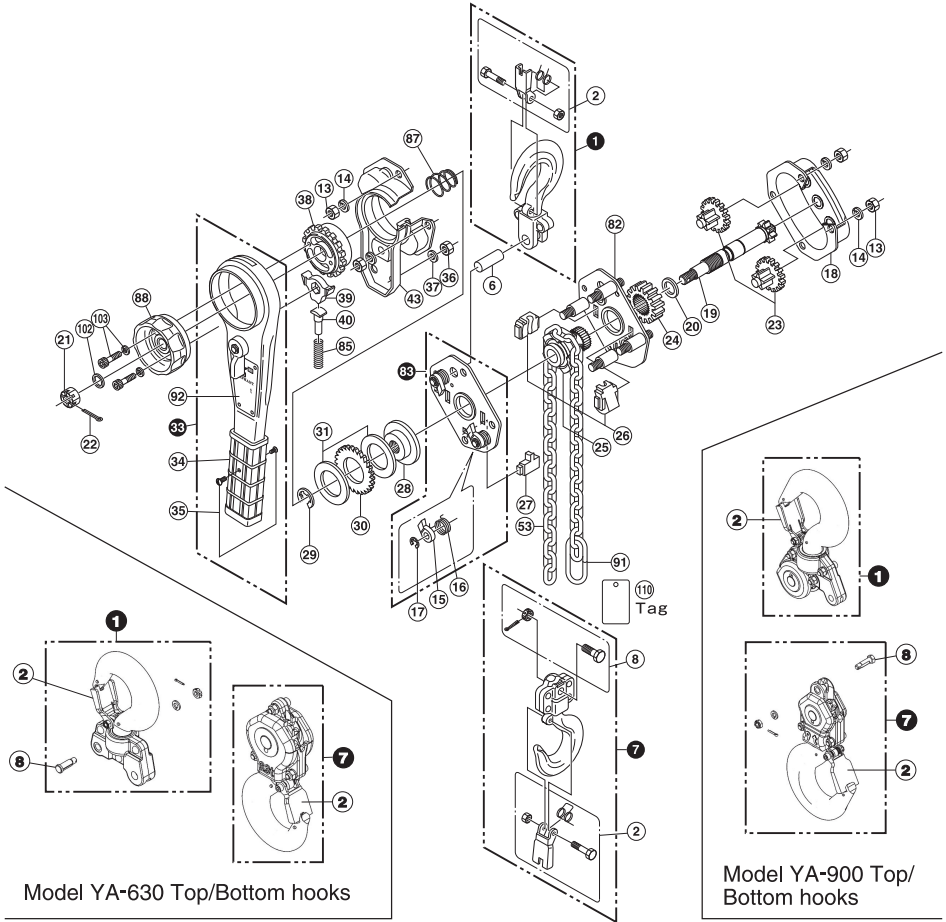

Model YA-630 Top/Bottom hooks

Model YA-900 Top/Bottom hooks

Symbols in Breakdown Schematics		Parts Names	Symbols in Breakdown Schematics		Parts Names	Symbols in Breakdown Schematics		Parts Names			
Set	Individual unit		Set	Individual unit		Set	Individual unit		Set	Individual unit	
1		Top hook ass'y	22		Cotter Pin	35		Bracket screw	17		E-ring for pawl
	2	Safety latch set	23		2nd and 3rd gear ass'y	92		Name plate	85		Ratchet spring
	6	Top hook pin	24		Load gear	36		Hex. nut	87		Spring for floating mechanism
7		Bottom hook ass'y	25		Load sheave	37		Spring washer	88		Feed handle
	2	Safety latch set	26		Chain guide ass'y	38		Feed gear	91		Chain stopper
	8	Chain stop bolt set	27		Chain stripper	39		Ratchet for feed gear	102		Check washer
	13	Hex. nut	28		Disk hub	40		Ratchet spring pin	103		Hex. socket head cap screw set
	14	Spring washer	29		E-ring for disc hub	43		Lever cover set	110		Tag
	18	Gear cover ass'y	30		Ratchet wheel	82		Gear-side plate ass'y	53		Load chain set
	19	Pinion shaft	31		Brake lining	83		Lever-side plate ass'y			
	20	Washer for pinion shaft	33		Lever ass'y	15		Pawl			
	21	Hex. castle nut	34		Lever grip	16		Pawl spring			

*Parts indicated with black lines are included in the parts with gray lines.

Example : Part No. 7, Bottom hook ass'y includes Part No. 2, Safety latch set and Part No. 8, Chain stop bolt set.

*The black line parts are also provided for sale individually.

*Only for Model YA-630, the chain stop bolt set is included in the top hook.

YA III

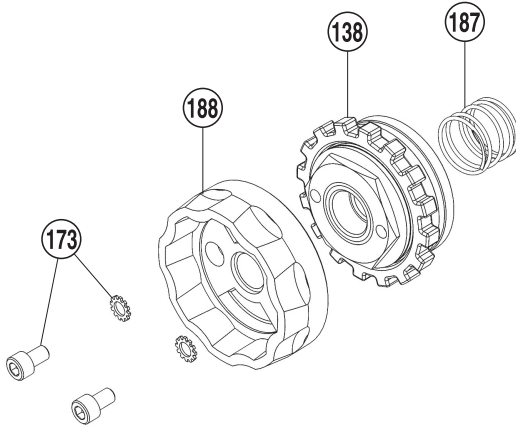

Symbols in Breakdown Schematics		Parts Names
Set	Individual unit	
	138	TORCON device set
	173	Hex. socket head cap screw set
	187	Spring for floating mechanism
	188	Feed handle

YAS

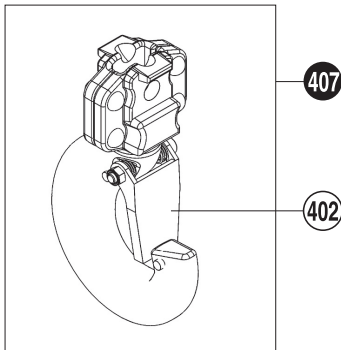
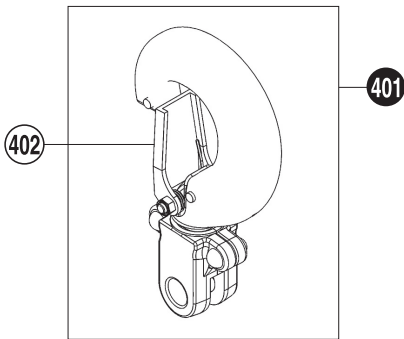

Symbols in Breakdown Schematics		Parts Names
Set	Individual unit	
401		Top hook ass'y
	402	Safety latch set
407		Bottom hook ass'y
	402	Safety latch set

YAR

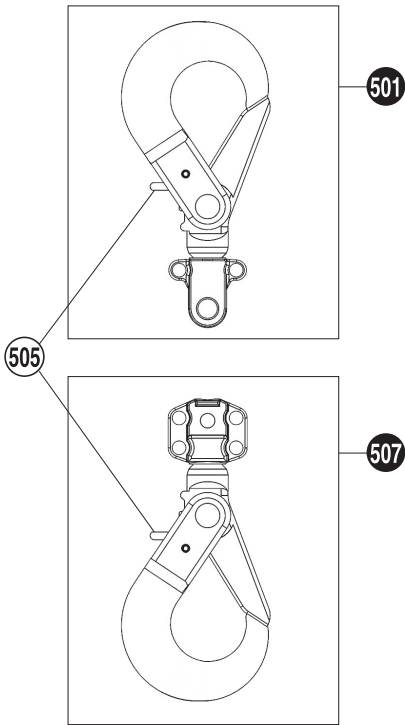

Symbols in Breakdown Schematics		Parts Names
Set	Individual unit	
501		Top hook ass'y
	505	Trigger set
507		Bottom hook ass'y
	505	Trigger set

Warranty

In this section, ELEPHANT CHAIN BLOCK CO., LTD is hereinafter referred to as "ELEPHANT".

In this section, Owners or Operators are hereinafter referred to as "Customer".

ELEPHANT warrants that the product (Manually Lever Operated Chain Hoist) manufactured and marketed by ELEPHANT will be free from defects in material and workmanship for the following period from the initial date of use by Customer.

Manually Lever Operated Chain Hoist 1 year

Customers are requested to write down the start date of use of the product on the cover of this Instruction Manual.

However, the product must be used in accordance with ELEPHANT's recommendations. In addition, the product must not be subjected to rough use, inadequate maintenance, misuse, careless use, incorrect repairs or modification. If ELEPHANT's inspection of the product reveals that the product has become defective in material and workmanship within the period indicated above, ELEPHANT agrees, at its sole discretion, to send and deliver the affected parts to the Customer for replacement free of charge (not including installation work).

The Customer must follow the instructions provided by ELEPHANT to obtain a return authorization prior to returning the product for warranty evaluation.

If you have a complaint about a product, please submit the product and the following documents.

- 1) Detailed description at the time of use
- 2) Photos or videos that show the usage status
- 3) Record of start date of use (cover of this manual)
- 4) Inspection record (based on ASME)
- 5) Product (stored as it was at the time of the accident and not disassembled)

In addition, the return shipment must be made with freight prepaid, to the address and in the shipping way directed by ELEPHANT.

After returning from repair, the product shall be warranted for the remainder of the original warranty period.

Replacement parts installed after the expiration of the original warranty period shall be warranted (not including installation labor) only for a period of one year from the date of installation.

If the product is found to be without defect or it is determined by ELEPHANT that the malfunction was caused by Customer's operating condition, the customer shall be responsible for the cost of returning the product. If ELEPHANT repairs the product according to the request of the customer, the customer shall be responsible for the cost of repair and returning the product.

ELEPHANT shall make no other express or implied (unwritten) warranties as to the suitability of the product or its applicability to particular purposes.

ELEPHANT shall not be liable for any loss or expense incurred in connection with the use of the product, resulting in death, injury to persons or property, or for incidental, special or consequential damage.

In addition, ELEPHANT shall not be liable for any loss or expense incurred as a result of any act or omission or for any other reason, whether due to negligence or intentional.

The goods has passed rigid inspection by us ahead of delivery in accordance with our standard in terms of test load and all other respects in good and satisfactory condition.

Inspector *J. Uryu*



ELEPHANT CHAIN BLOCK CO.,LTD.

**180 Iwamuro 2-chome, Osaka-Sayama-City,
Osaka, Postal code 589-8502, JAPAN
Phone : 072-365-7778 Fax : 072-365-7869**