

Load Chain Maker Developed New Age Highest Grade

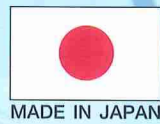

Lever Hoist YA

**Strongest Load chain
ever than before**

B39 VH

YA is equipped with new
developed load chain
Grade V 100kgf/mm².

Improved shape of lever
Round shape lever handle
brings easy operation.

Round-shape lever



Patent and copyright registered.

**Stronger hooks and
safety latch**

Tip-supporting safety latch
brings easy handling.

**Single action
free spooling**
When loading,
automatically
brakes.

**Safety latch and
unique hook shape**

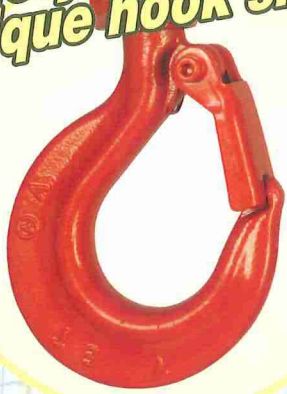

ELEPHANT

Specialized manufacturer of highest grade hoist chain

B39 VH, VHC H39 DAT

Dimensions

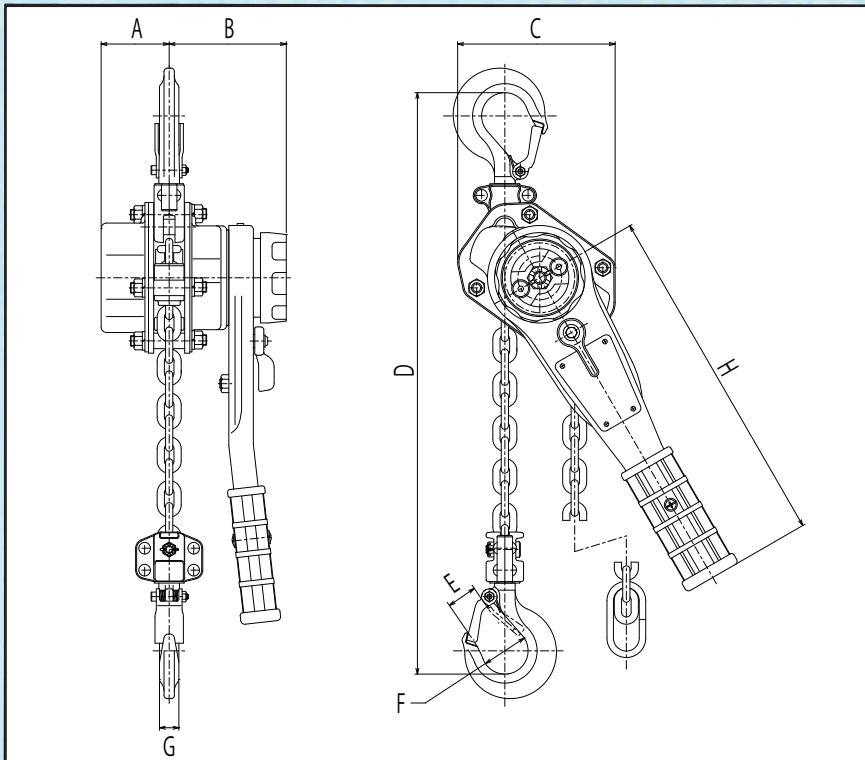

Model	A	B	C	D	E	F	G	H
YA-80	53	91	122	290	23	36	15	268
YA-100	53	91	122	312	28	43	16	268
YA-160	63	99	136	352	29	43	21	310
YA-320	82.5	104	180	420	36	53	28	310
YA-630	82.5	104	235	564	47	70	34	310
YA-900	82.5	104	300	689	73	85	47.5	310

Specifications

Model	Capacity	Standard lift	Hand effort to lift full working load	Diameter of load chain	Net weight
YA-80	0.8 t	1.5m	30kg	5.6mm	6.0kg
YA-100	1t	1.5m	37kg	5.6mm	6.2kg
YA-160	1.6 t	1.5m	36kg	7.1mm	9.2kg
YA-320	3.2 t	1.5m	44kg	9mm	15.5kg
YA-630	6.3 t	1.5m	45kg	9mm × 2	26.5kg
YA-900	9 t	1.5m	46kg	9mm × 3	42kg

All specifications herein are subject to change without notice.



ELEPHANT CHAIN BLOCK CO.,LTD.

180,Iwamuro 2-chome, Osaka-sayama city, Osaka, Japan

E-mail: elp_trade@elephant.co.jp

URL <http://www.elephant.co.jp/english/index.html>