

1 2 3 4 5 6 7 8 9

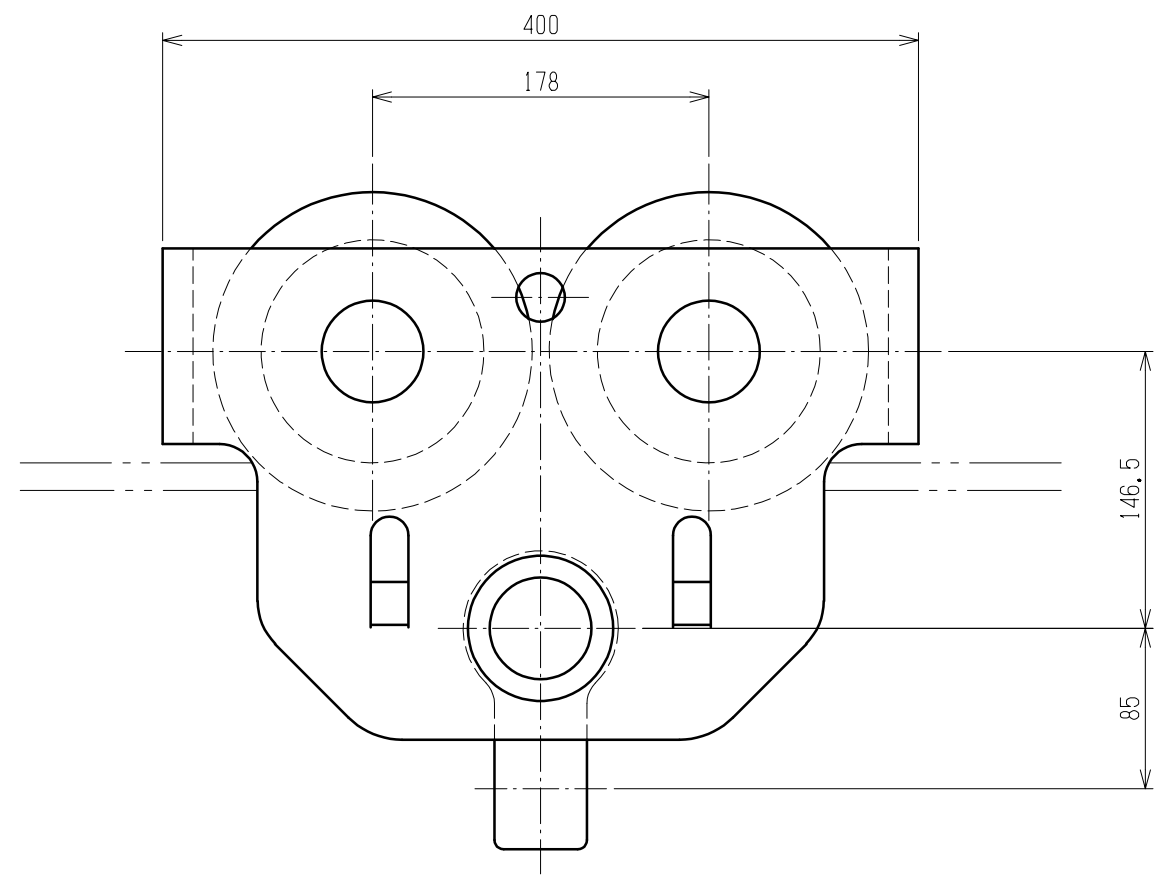
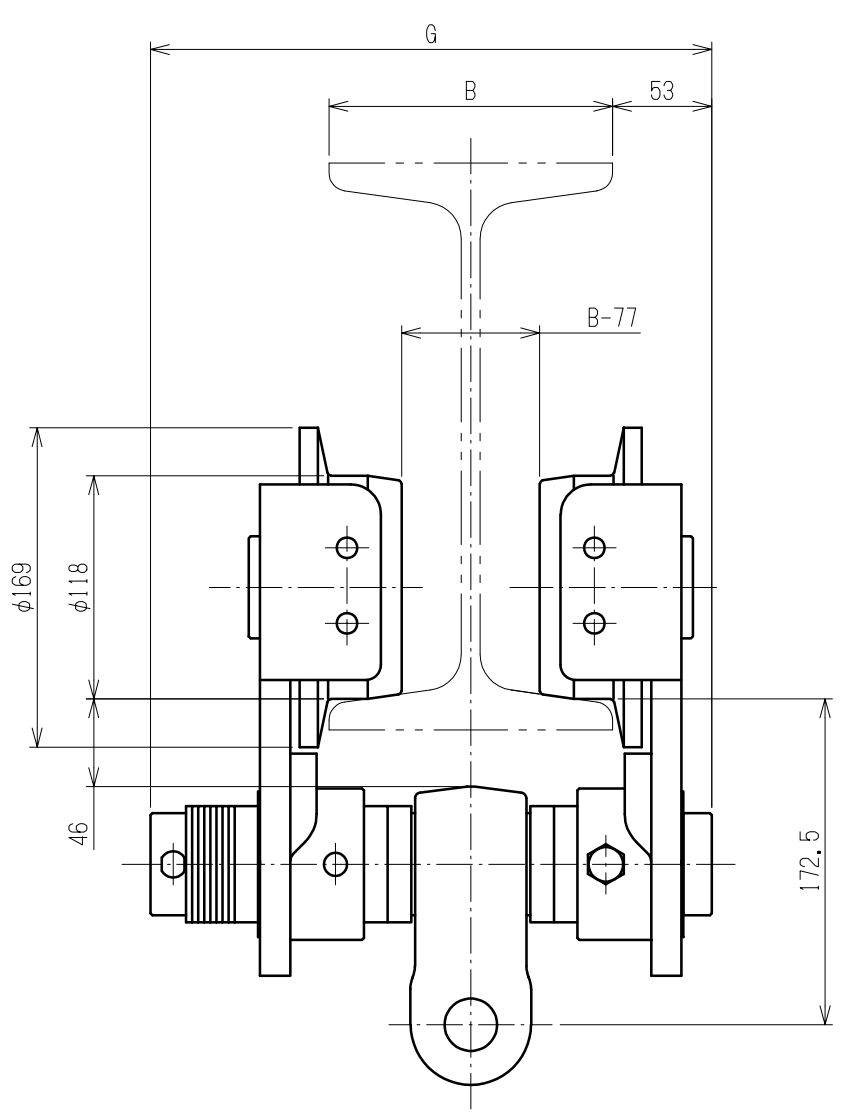

Particulars		
Nominal Capacity	5 t	
Min. Radius for Curve	2300 mm	2400 mm
Flange Width : B	* 100~178mm	179~305mm
Max. Dimension of Trolley Width : G	297 mm	412 mm
Mass	50 kg	

Note:  
 For Electric Chain Hoist  
 The trolley can be installed on either tapered or flat flange.  
 Mass is when the flange width is assumed to be as marked (\*).

					APPROVED	CHECKED	DESIGNED	DRAWN
					T. Hiroshima	T. Ogata	M. Ono	M. Ono
					2024. 04. 26	2024. 04. 26	2024. 04. 26	2024. 04. 26
REV.	QTY	C O N T E N T S			DATE	DRAWN	APPROVED	

TITLE			
5t TS SERIES PLAIN TROLLEY			
CODE	TSP050	SCALE	1:4
DWG. NO.	T7PE050-12100	REV.	0

