

1 2 3 4 5 6 7 8 9

A

B

C

D

E

F

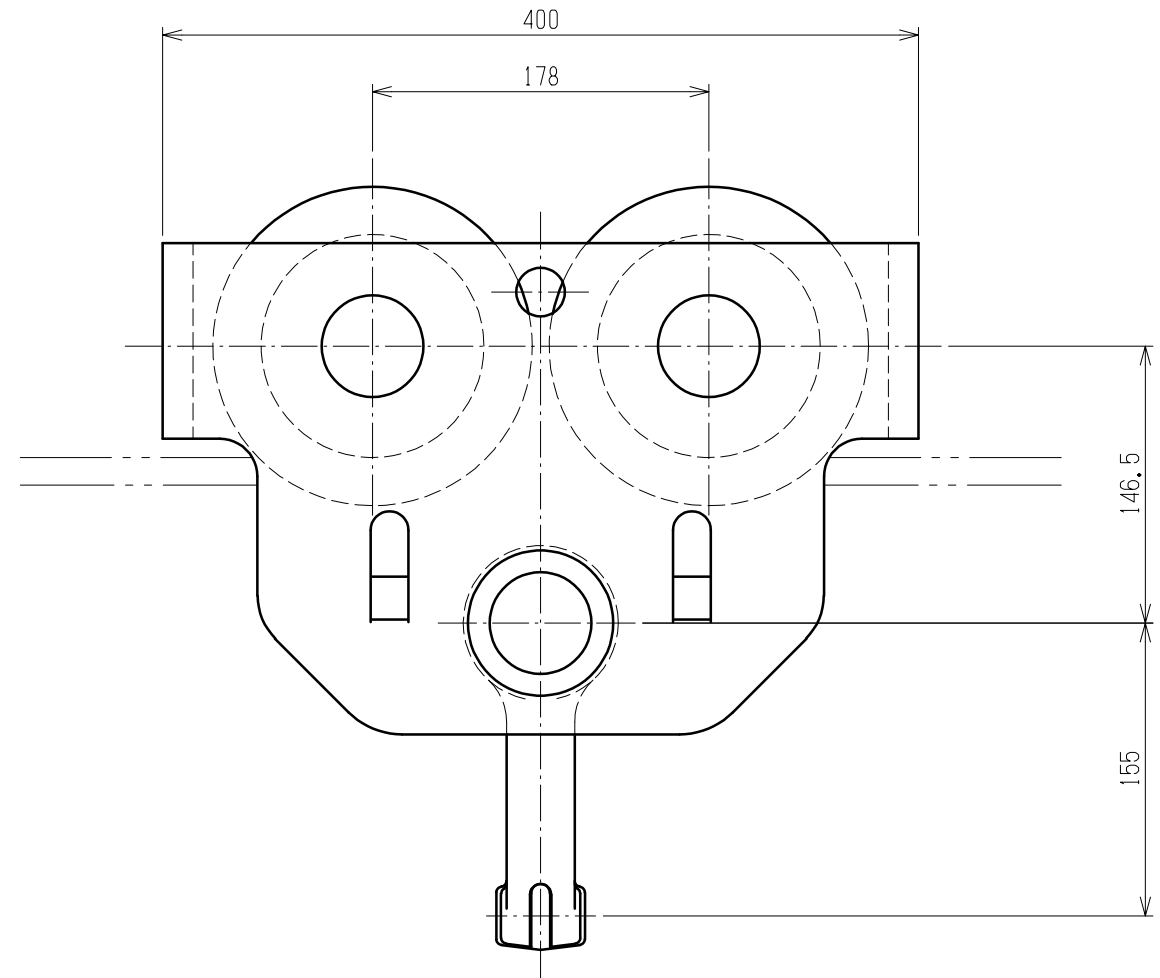
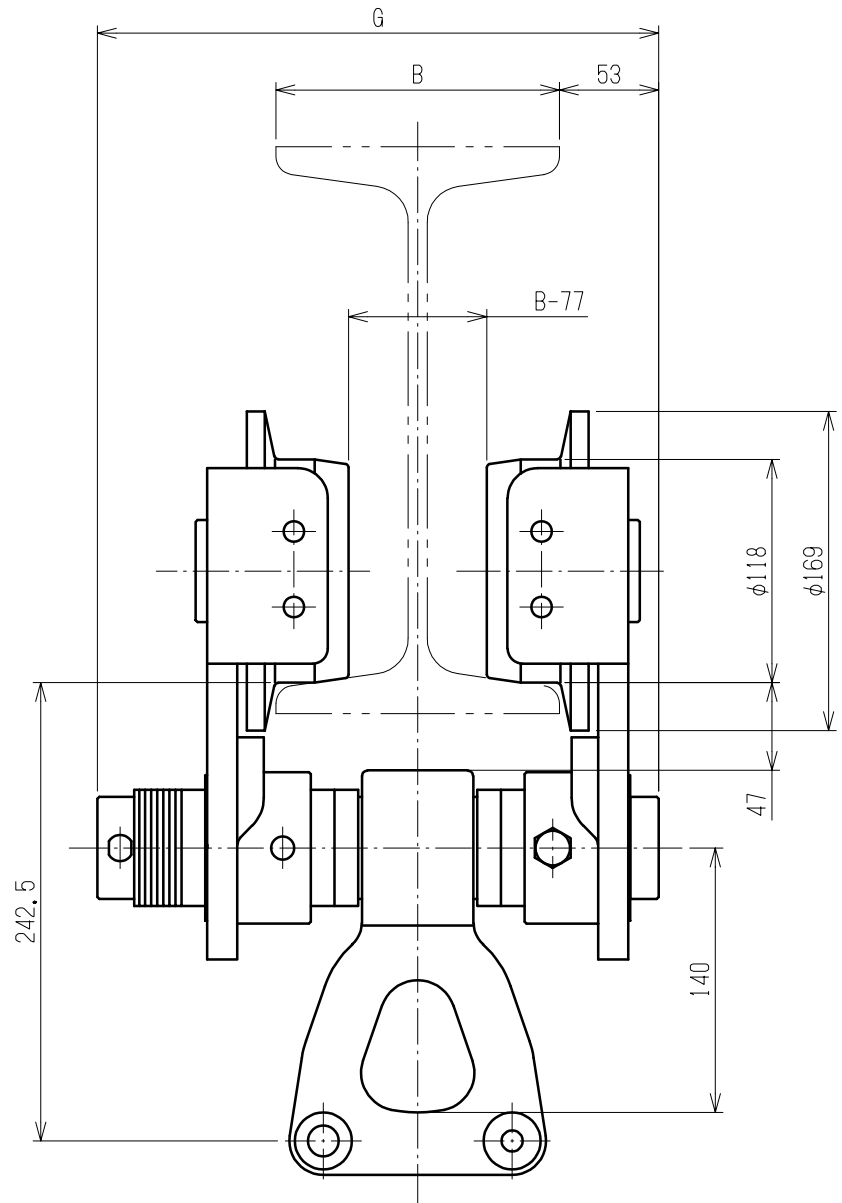

Particulars		
Nominal Capacity	5 t	
Min. Radius for Curve	2300 mm	2400 mm
Flange Width : B	* 100~178mm	179~305mm
Max. Dimension of Trolley Width : G	297 mm	412 mm
Mass	50 kg	

Note:
 For Manual Chain Hoist
 The trolley can be installed on either tapered or flat flange.
 Mass is when the flange width is assumed to be as marked (*).

					APPROVED	CHECKED	DESIGNED	DRAWN
					T. Hiroshima	T. Ogata	M. Ono	M. Ono
					2024. 04. 26	2024. 04. 26	2024. 04. 26	2024. 04. 26
REV.	QTY	CONTENTS			DATE	DRAWN	APPROVED	

TITLE			
5t TS SERIES PLAIN TROLLEY			
CODE	TSP050	SCALE	1:4
DWG. NO.	T7PF050-12100	REV.	0

