

» Light Weight & Easy Handling

SKC150(M) • SKC250(W) • SKC1250D

LIFTING CLAMP FOR CONCRETE MATERIAL  
(Manual / Machine Type)

CHECK!



Operation manual & parts drawing

Example of use

⚠ Always lift a load at 2 or more points for safety.

Manual type

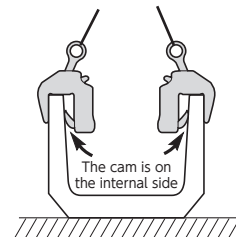
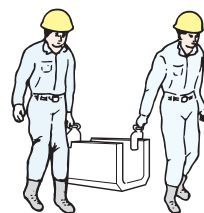

Machine type

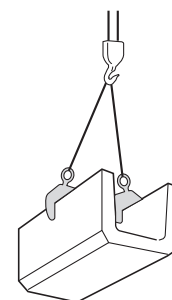
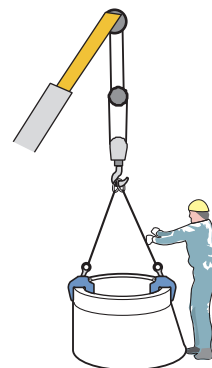

\* SKC1250D (deep wide type) shows its great power especially for lifting assembly sewage manhole.

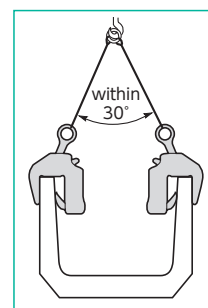

Features

- Ideal for lifting and handling concrete materials like reinforced concrete U shaped gutters, single side thick U shaped gutters, U flumes.
- Compact, light-weight and easy to handle.
- Including a mechanism making that the clamping force increases in proportion to the load weight.
- One touch open/close mechanism for easy operation.

Cam types, pad types

Manual, machine types

Adjustable clamp range types, balances

Internal expanding lifting clamps for U shaped gutter

Batch lifting clamps for bank block

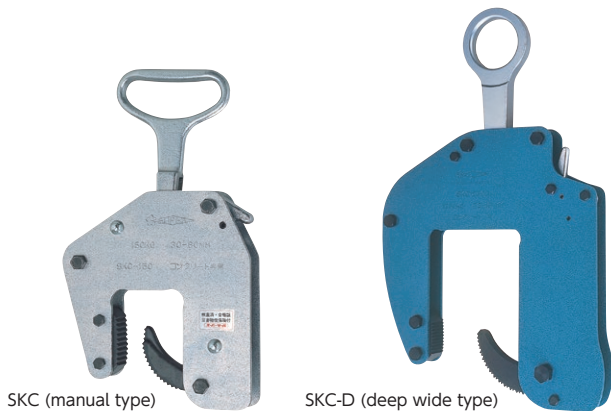

SKC (manual type)

SKC-D (deep wide type)

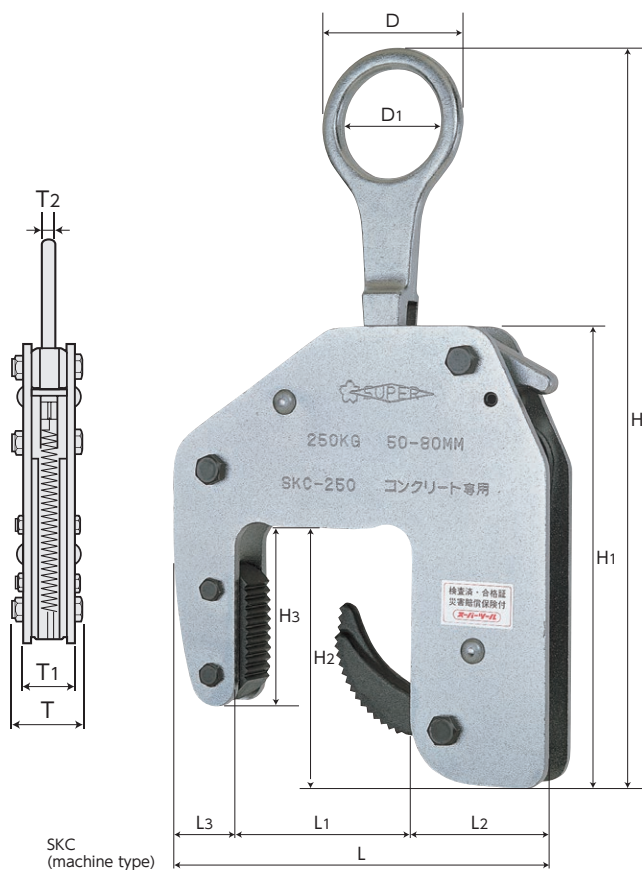

Item No.	Item type	Rated capacity (kg)	Clamp range (mm)	Size (mm)													N.W. (kg)
				L	L1	L2	L3	H	H1	H2	H3	D	D1	T	T1	T2	
SKC150	Manual type	150	30~60	185	65	65	55	258~312	200	108	83	112	—	44.5	31	16	3
SKC150M	Machine type	150	30~60	185	65	65	55	274~328	200	108	83	70	50	44.5	31	10	3
SKC250	Machine type	250	50~80	190	85	66	39	278~332	205	112	85	70	50	44.5	32	10	3
SKC250W	Machine type	250	70~100	210	105	66	39	278~332	205	112	85	70	50	44.5	32	10	3.5
SKC1250D	Deep wide type	1250	73~137	355	145	125	80	477~558	385	242.5	192.5	100	70	60.5	37	18	10