



# **Panel Lifting Clamp for Housing**

**PTC100, PTC200,  
PSC100, PTC250,  
PTC150**

## **Operation Manual**

This operation manual explains the basic operation and handling of the clamps. Please read this manual carefully before use and observe the precautions for safe operation.

**SUPER TOOL CO., LTD.**

 brand panel lifting clamps are energy-saving lifting equipment which have been developed for the purpose of transportation of panel and beams.

## **Proper use**

Operate lifting clamps after carefully reading and understanding this instruction manual for enhancing efficiency and safety of operation.

## **Prime efficiency and economy**

Advanced functions, reasonableness and versatile applications of finely and carefully designed  lifting clamps ensure prime efficiency and economy.

## **Special considerations on safety**

We conduct a pulling test with a load three times (or twice) of rated capacity and a manufacturing serial number is marked on each product, thus directing a special attention to safety.

# Precautions for safety operation

## Be sure to read this instruction manual carefully before use.

Mistaken use of lifting clamp may cause a danger such as dropping of load.

Education of “crane safety regulations,” “operation manual for lifting clamp,” “your company’s operation standards,” etc. should be given before actual operation not only to business owners who have purchased clamps but also to their operators to ensure that actual operators have acquired enough knowledge, safety information, and precautions of the clamps.

Safety precautions are divided into two classifications in this manual; “Warning” and “Caution,”.



### **WARNING:**

Indicates a potentially hazardous situation which, if not avoided, could result in death or serious injury.





### **CAUTION:**

Indicates a potentially hazardous situation which, if not avoided, could result in medium damage or slight injury, or could result in property damage.

While only mentioned in  CAUTION, failure to comply with them still may lead to a serious disaster. As such, do not fail to pay attention both to WARNING and CAUTION which are of great importance.

## Meanings of Signs

The signs of  and  indicate that precautions should be taken.

The contents of warning or caution are described at each sign.



The sign of  indicates prohibited actions.

The sign of  indicates that an action is enforced or instructed.







Two point lift for  righthand figure.

※ After reading this manual, make sure to keep it at a place of easy access by any users.







# 1. Handling in general

 <b>WARNING</b>	
<ul style="list-style-type: none"> <li>● Do not operate until the contents of the operation manual, and caution tag/plate are thoroughly read and understood.</li> <li>● Do not operate without a legal qualification.</li> <li>● Be sure to clear of the area of the operation for lifting or turning a load against possible drop off or fall over.</li> <li>● Do not use for other than intended purpose.</li> </ul>	 Prohibited
<ul style="list-style-type: none"> <li>● Make sure to execute an inspection periodically and before each operation.</li> </ul>	 Instructed



# 2. Check before operation





 <b>WARNING</b>	
<ul style="list-style-type: none"> <li>● Do not use clamp unsuitable for the operation method.</li> <li>● Do not use clamp of an abnormal condition; deformed, cracked, worn, malfunctioning, etc.</li> <li>● If the load is under the following conditions, do not use clamp. (A material of fragile, high-hardness, low-hardness or extremely low-hardness, or a member with the gripping part tapered down more than 8°)</li> </ul>	 Prohibited
<ul style="list-style-type: none"> <li>● Check the type, rated capacity, clamp range, and “periodic inspection completed” label displayed on clamp body.</li> <li>● The load to be lifted shall be within an allowable range of rated capacity of clamp.</li> <li>● Thickness of load shall be within designated clamping range.</li> </ul>	 Instructed
 <b>CAUTION</b>	
<ul style="list-style-type: none"> <li>● Do not use clamp for the load under the following conditions. (Load to be lifted is more than 150°C, or in an atmosphere or solution of acid or alkaline chemicals less than minus 20°C)</li> </ul>	 Prohibited
<ul style="list-style-type: none"> <li>● Sling to be used for the clamp shall be an appropriate one for lifting operation.</li> </ul>	 Instructed

### 3. Lifting operation





 <b>WARNING</b>	
<ul style="list-style-type: none"> <li>● Do not use clamp, lifting at one point. (excluding special or custom ordered products)</li> <li>● Do not use the clamp in the following ways of lifting: lifting of two or more individual objects at one time. (overlapped loads, padded load etc. , or side gripping)</li> <li>● Do not use the clamp for pulling out steel plate sheet from the steel sheet pile or for vertical lifting of the sheet.</li> <li>● Do not use the clamp when strong wind may threaten to cause any danger.</li> <li>● Do not use the clamp for a hydraulic shovel.</li> </ul>	 Prohibited
<ul style="list-style-type: none"> <li>● Install two or more clamps in a balanced way to keep the balance of load.</li> </ul>	 Two point lift
<ul style="list-style-type: none"> <li>● The lifting angle of the clamps and the dividing angle should be kept within the allowable angles according to types. Load should be inserted to the innermost end of the jaw opening.</li> <li>● When you use the clamp with a lock mechanism, never fail to have the lock engaged.</li> </ul>	 Instructed
 <b>CAUTION</b>	
<ul style="list-style-type: none"> <li>● If oil, paint, scale, rust, etc. are on the gripping pad, do not use the clamp.</li> <li>● Do not drop clamp or drag on the ground.</li> </ul>	 Prohibited

### 4. Operation of a crane

 <b>WARNING</b>	
<ul style="list-style-type: none"> <li>● Never lift a load exceeding the rated capacity.</li> <li>● Do not operate a crane in such a way as to give an impact to the load or the clamp.</li> <li>● Do not allow a person to stand on the load or to carry him.</li> <li>● Do not lift a load which is not free from any other objects.</li> <li>● Do not release the lock of clamp while lifting load.</li> <li>● Avoid unintended contact by load to an adjacent member or to the clamp, which has been removed from the load.</li> </ul>	 Prohibited

<ul style="list-style-type: none"> <li>● Stop the lifting operation by crane for a moment when the load is applied to the lifting ring for safety checking. (depth of the load into the clamp opening; status of locking).</li> <li>● Stop the operation of the crane just before the load reaches the ground, and check the following matters: (Inclination or falling over of the load and security around the landing area of the load)</li> </ul>	 Instructed
 <b>CAUTION</b>	
<ul style="list-style-type: none"> <li>● Do not operate the crane in such a way as to drag the load along the ground.</li> <li>● Do not leave the crane (or winder, etc.) unattended from an operating position while keeping the load lifted with the clamp.</li> </ul>	 Prohibited
<ul style="list-style-type: none"> <li>● Raising and lowering operation by crane should be done slowly and carefully.</li> </ul>	 Instructed

## 5. Maintenance, storage and alteration

 <b>WARNING</b>	
<ul style="list-style-type: none"> <li>● Never alter the clamp and its accessories.</li> <li>● Do not apply welding or heat to the clamp or its accessories.</li> <li>● Do not use any other parts than our company's genuine parts.</li> <li>● Clamps which require the repair should be stored at a different place so that they are not used mistakenly.</li> </ul>	 Prohibited
<ul style="list-style-type: none"> <li>● Persons with specialized knowledge designated by the business owner are to conduct maintenance and repairing work.</li> <li>● When any abnormality with the clamp is found, do not use it and immediately repair or dispose.</li> <li>● Remove, if any, paint or mud sticking to the moving parts of the clamp, cams, and pads.</li> </ul>	 Instructed
 <b>CAUTION</b>	
<ul style="list-style-type: none"> <li>● Conduct maintenance and repairing without any load attached.</li> <li>● Conduct maintenance and repairing after posting a sign indicating that you're on the maintenance work.</li> <li>● Never fail to lubricate oil on the rotating parts of the clamp (around the pins), guide grooves, sliding parts, etc.</li> <li>● Be sure to store clamps indoor.</li> </ul>	 Instructed

## ■ Uses

**Clamps suitable for lifting, transportation, and construction work of panels for housing.**

Item No.	Uses
<b>PTC100</b>	This unit is optimal for lifting, movement, construction work for siding boards, external-wall panels, mold forms, insulating external-wall materials, wooden panels, etc. Do not use for lifting ALC panels or extruded molding plates. Not for use on various concrete products, tile panels, glass panels, stone panels, metal panels, etc.
<b>PSC100</b>	Can be used for various interior and exterior panels. Note that collapsible (fragile) panels that do not contain aggregate (reinforcing steel) or other materials cannot be used. Not for use on various concrete products, tile panels, glass panels, stone panels, metal panels, etc.
<b>PTC150</b> <b>PTC200</b>	This unit is optimal for lifting, movement, construction work for panels for two-by-four construction method and beams for wooden housing. Do not use for lifting ALC panels or extruded cement panels. Not for use on various concrete products, tile panels, glass panels, stone panels, metal panels, etc.
<b>PTC250</b>	This unit is optimal for lifting, movement, construction work for panels for two-by-four or two-by-six construction method and beams for wooden housing. Do not use for lifting ALC panels or extruded cement panels. Not for use on various concrete products, tile panels, glass panels, stone panels, metal panels, etc.

## ■ Features

1. Compact, light-weight, and easy to use.
2. In proportion to lifting load, fastening strength increases, clamping the load securely.
3. The clamping range is wide, and it is adjustable with an adjustment plate pin.
4. Because of the spikes attached on the movable pads (panel-clamped part), there occurs no slipping between the panel and the clamp, ensuring safety execution.
5. Polyurethane rubber is used for the fixed pad, so the front side of the panel is not susceptible to bruise.
6. Working efficiency can be enhanced as the fastening lock can be unlocked by remote operation.

## ■ Specifications

Item No.	Rated Capacity	Clamp Range	Net Weight
<b>PTC100</b>	100kg	5-stage adjustment type ① 5～ 20mm ② 20～ 35mm ③ 35～ 50mm ④ 50～ 65mm ⑤ 65～ 80mm	1.8kg
<b>PSC100</b>	100kg	2-stage adjustment type ① 0～ 20mm ② 20～ 40mm	3.5kg
<b>PTC150</b>	150kg	4-stage adjustment type ① 60～ 80mm ② 80～100mm ③ 100～120mm ④ 120～140mm	3.6kg
<b>PTC200</b>	200kg	5-stage adjustment type ① 35～ 55mm ② 55～ 75mm ③ 75～ 95mm ④ 95～115mm ⑤ 115～135mm	4.0kg
<b>PTC250</b>	250kg	5-stage adjustment type ① 80～100mm ② 100～120mm ③ 120～140mm ④ 140～160mm ⑤ 160～180mm	5.8kg



# REPLACEMENT PARTS AND ASSEMBLIES

## ● PTC 100

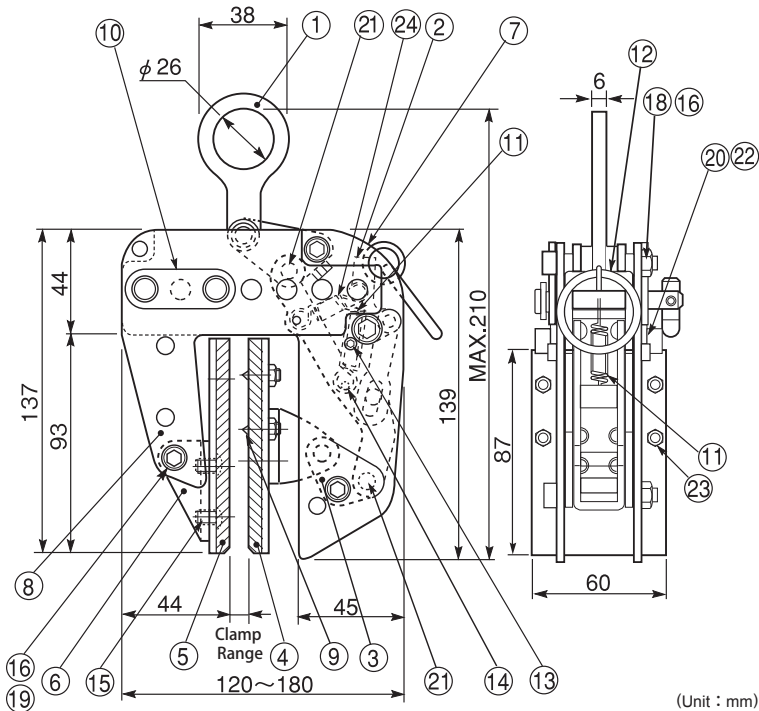

(Unit : mm)

Part No.	Part Name	Item No.	Q'ty (pc)	Part No.	Part Name	Item No.	Q'ty (pc)
Shackle Assembly				Movable Pad Assembly			
1	Shackle	PTH	1	4	Movable Pad	PTCE	1
18	Hex. Hole Head Bolt	PTCN	1	9·23	Spike, Nut	PTCG	5
16	U-nut		1	15	Hex. Hole Disc Bolt	PTCM	4
Lock Lever Link Assembly				Fixed Pad Assembly			
2	Lock Lever Link	PTF	1	5	Fixed Pad	PTCR	1
11·24	Spring (large/small)	PTCF	1	6	Fixed Pad Mounting Bracket	PTCQ	1
12	Handgrip Link (with key ring)		1	15	Hex. Hole Disc Bolt	PTCM	4
14	Spring Pin		3	19	Hex. Hole Head Bolt	PTCV	1
13	Hex. Hole Head Bolt	PTCA	2	16	U-nut		1
20	Hex. Hole Head Bolt	PTCD	2	8	Arm	PTCJ	1
21	Straight Pin	PTCP	1	10	Adjustment Plate Pin	PTCK	1
22	Spring Washer	PTCY	2		Rope	PTCU	1
Cam Assembly				⑦ is the main body and not for sale.			
3	Cam	PTCT	1	<b>Individual parts available</b>			
18	Hex. Hole Head Bolt	PTCN	1	Part No.	Part Name	Item No.	Q'ty (pc)
16	U-nut		1	11·24	Spring (large/small)	PTCS	1
21	Straight Pin	PTCP	1	12	Handgrip Link (with key ring)	PTCL	1

When ordering, add 100 after Item No.

# ● PSC 100

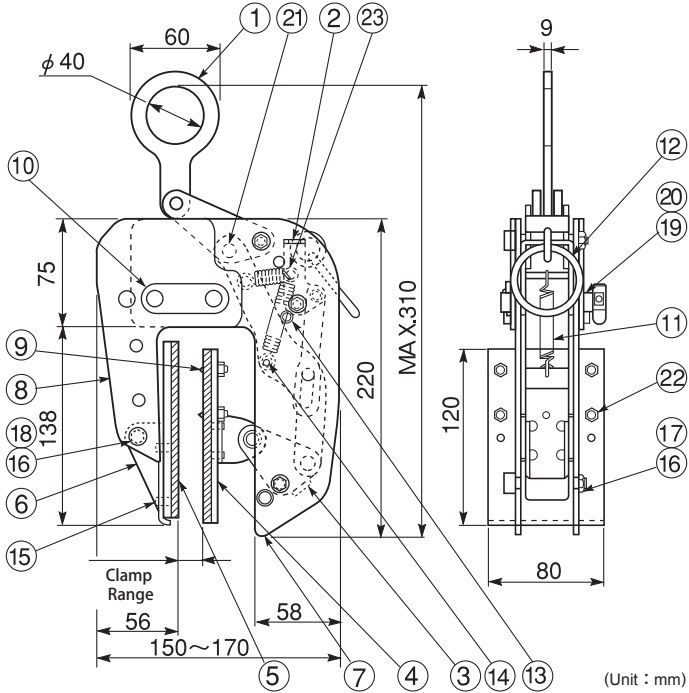

(Unit : mm)

Part No.	Part Name	Item No.	Q'ty (pc)	Part No.	Part Name	Item No.	Q'ty (pc)
Shackle Assembly				Movable Pad Assembly			
1	Shackle	PTH	1	4	Movable Pad	PTCE	1
17	Hex. Hole Head Bolt	PTCN	1	9*22	Spike, Nut	PTCG	5
16	U-nut		1	15	Hex. Hole Disc Bolt	PTCM	4
Lock Lever Link Assembly				Fixed Pad Assembly			
2	Lock Lever Link	PTCF	1	5	Fixed Pad	PTCR	1
11*23	Spring (large/small)		1	6	Fixed Pad Mounting Bracket	PTCQ	1
12	Handgrip Link (with key ring)		1	15	Hex. Hole Disc Bolt	PTCM	4
14	Spring Pin		3	18	Hex. Hole Head Bolt	PTCV	1
13	Hex. Hole Head Bolt	PTCA	2	16	U-nut		1
19	Hex. Hole Head Bolt	PTCD	2	8	Arm	PTCJ	1
20	Spring Washer	PTCY	2	10	Adjustment Plate Pin	PTCK	1
21	Straight Pin	PTCP	1		Rope	PTCU	1
Cam Assembly				⑦ is the main body and not for sale.			
3	Cam	PTCT	1	<b>Individual parts available</b>			
17	Hex. Hole Head Bolt	PTCN	1	Part No.	Part Name	Item No.	Q'ty (pc)
16	U-nut		1	11*24	Spring (large/small)	PTCS	1
21	Straight Pin		PTCP	1	12	Handgrip Link (with key ring)	PTCL

All parts except No. 8 Arm are common to PTC150.

# ● PTC 150

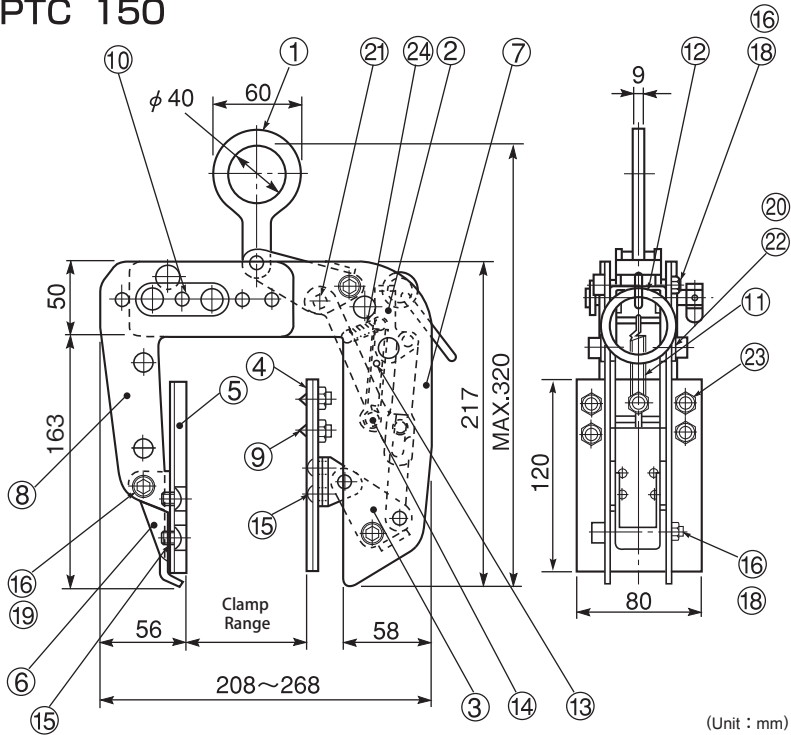

(Unit : mm)

Part No.	Part Name	Item No.	Q'ty (pc)	Part No.	Part Name	Item No.	Q'ty (pc)
Shackle Assembly				Movable Pad Assembly			
1	Shackle	PTH	1	4	Movable Pad	PTCE	1
18	Hex. Hole Head Bolt	PTCN	1	9·23	Spike, Nut	PTCG	5
16	U-nut		1	15	Hex. Hole Disc Bolt	PTCM	4
Lock Lever Link Assembly				Fixed Pad Assembly			
2	Lock Lever Link	PTF	1	5	Fixed Pad	PTCR	1
11·24	Spring (large/small)	PTCF	1	6	Fixed Pad Mounting Bracket	PTCQ	1
12	Handgrip Link (with key ring)		1	15	Hex. Hole Disc Bolt	PTCM	4
14	Spring Pin		3	19	Hex. Hole Head Bolt	PTCV	1
13	Hex. Hole Head Bolt	PTCA	2	16	U-nut	PTCJ	1
20	Hex. Hole Head Bolt	PTCD	2	8	Arm		1
21	Straight Pin	PTCP	1	⑦ is the main body and not for sale.			
22	Spring Washer	PTCY	2				
Cam Assembly				Rope			
3	Cam	PTCT	1	10	Adjustment Plate Pin	PTCK	1
18	Hex. Hole Head Bolt	PTCN	1	Individual parts available			
16	U-nut		1	Part No.	Part Name	Item No.	Q'ty (pc)
21	Straight Pin	PTCP	1	11·24	Spring (large/small)	PTCS	1
When ordering, add 150 after Item No.							
				12	Handgrip Link (with key ring)	PTCL	1

# ● PTC 200

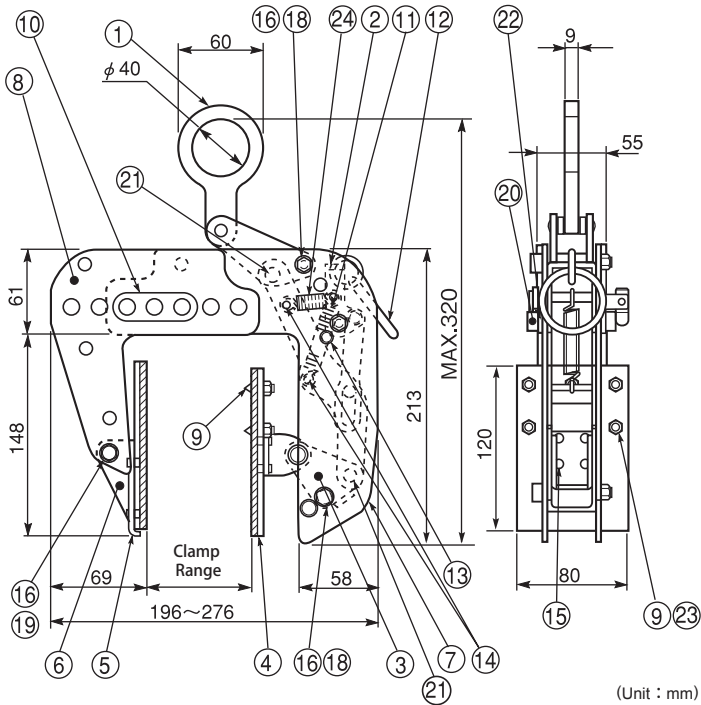

(Unit : mm)

Part No.	Part Name	Item No.	Q'ty (pc)	Part No.	Part Name	Item No.	Q'ty (pc)
Shackle Assembly				Movable Pad Assembly			
1	Shackle	PTH	1	4	Movable Pad	PTCE	1
18	Hex. Hole Head Bolt	PTCN	1	9*23	Spike, Nut	PTCG	5
16	U-nut		1	15	Hex. Hole Disc Bolt	PTCM	4
Lock Lever Link Assembly				Fixed Pad Assembly			
2	Lock Lever Link	PTCF	1	5	Fixed Pad	PTCR	1
11*24	Spring (large/small)		1	6	Fixed Pad Mounting Bracket	PTCQ	1
12	Handgrip Link (with key ring)		1	15	Hex. Hole Disc Bolt	PTCM	4
14	Spring Pin		3	19	Hex. Hole Head Bolt	PTCV	1
13	Hex. Hole Head Bolt	PTCA	2	16	U-nut		1
20	Hex. Hole Head Bolt	PTCD	2	8	Arm	PTCJ	1
21	Straight Pin	PTCP	1	10	Adjustment Plate Pin	PTCK	1
22	Spring Washer	PTCY	2		Rope	PTCU	1
Cam Assembly				⑦ is the main body and not for sale.			
3	Cam	PTCT	1	<b>Individual parts available</b>			
18	Hex. Hole Head Bolt	PTCN	1				
16	U-nut		1	Part No.	Part Name	Item No.	Q'ty (pc)
21	Straight Pin	PTCP	1	11*24	Spring (large/small)	PTCS	1
When ordering, add 200 after Item No.				12	Handgrip Link (with key ring)	PTCL	1

# ● PTC250

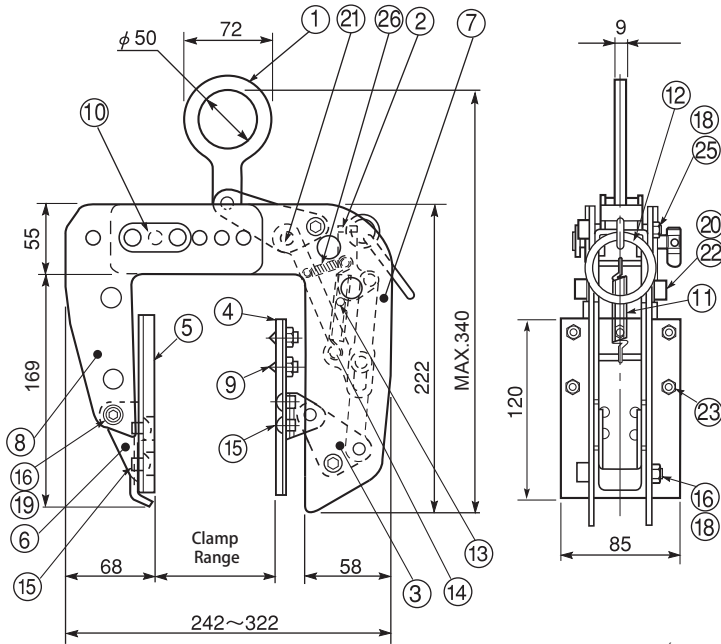

(Unit : mm)

Part No.	Part Name	Item No.	Q'ty (pc)	Part No.	Part Name	Item No.	Q'ty (pc)
Shackle Assembly				Movable Pad Assembly			
1	Shackle	PTH	1	4	Movable Pad	PTCE	1
18	Hex. Hole Head Bolt	PTCZ	1	9·23	Spike, Nut	PTCG	5
25	U-nut		1	15	Hex. Hole Disc Bolt	PTCM	4
Lock Lever Link Assembly				Fixed Pad Assembly			
2	Lock Lever Link	PTF	1	5	Fixed Pad	PTCR	1
11·26	Spring (large/small)	PTCS	1	6	Fixed Pad Mounting Bracket	PTCQ	1
12	Handgrip Link (with key ring)	PTCL	1	15	Hex. Hole Disc Bolt	PTCM	4
13	Hex. Hole Head Bolt	PTCA	2	19	Hex. Hole Head Bolt	PTCV	1
14	Spring Pin	PTCB	3	16	U-nut		1
20	Hex. Hole Head Bolt	PTCD	2		Rope	PTCU	1
21	Straight Pin	PTCP	1	8	Arm	PTCJ	1
22	Spring Washer	PTCY	2	10	Adjustment Plate Pin	PTCK	1
Cam Assembly				⑦ is the main body and not for sale.			
3	Cam	PTCT	1	<b>Individual parts available</b>			
18	Hex. Hole Head Bolt	PTCN	1	Part No.	Part Name	Item No.	Q'ty (pc)
16	U-nut		1	11·26	Spring (large/small)	PTCS	1
21	Straight Pin	PTCP	1	12	Handgrip Link (with key ring)	PTCL	1

When ordering, add 250 after Item No.

## ■ How to use

Use and operate the clamps in the following procedure.

1. Attach the remote control rope as shown in the figure on the right.

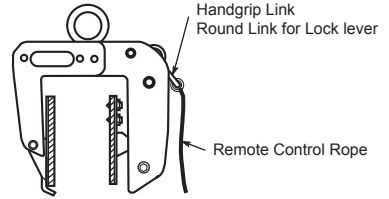

2. Adjust the clamp range according to the thickness of the panel to be clamped by changing the positions of the adjustment plate pin. Set the adjustment plate pin at the right position in the figure below by selecting an appropriate one of the punch-marked indications of clamping ranges. Further, when you newly pull out and insert the adjustment plate pin, insert it all through the main body to the end with the toggle head outside.

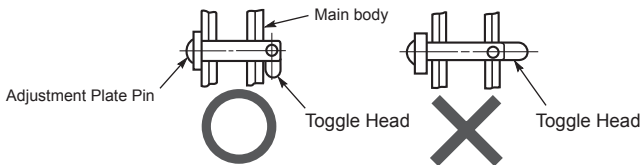

### ① PTC100

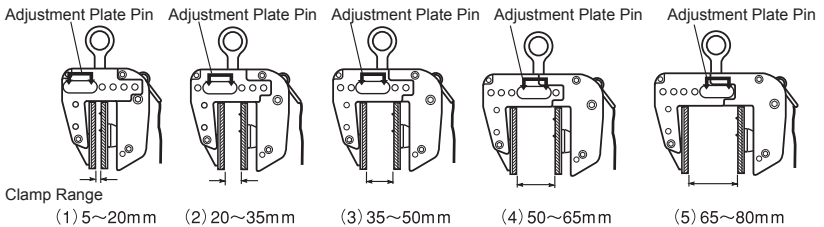

### ② PSC100

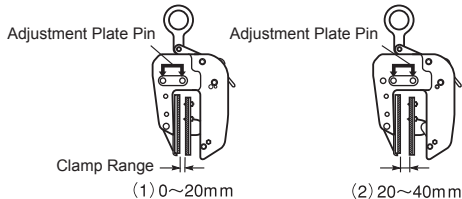

### ③ PSC150

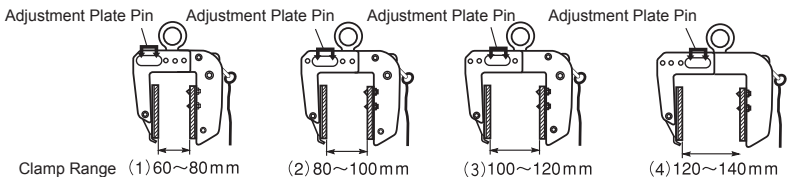

#### ④ PTC200

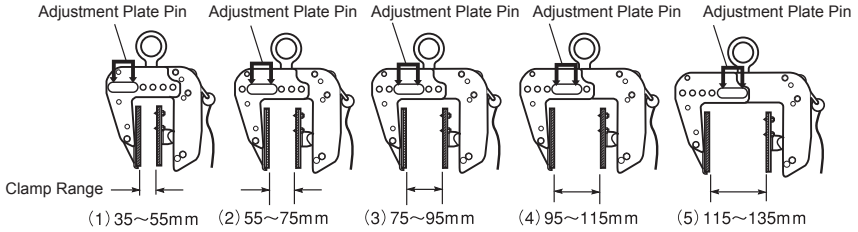

#### ⑤ PTC250

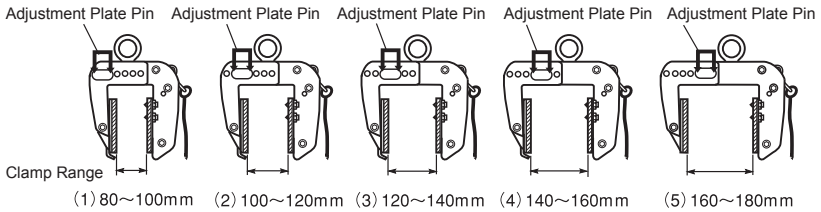

3. Pull down the lock lever and confirm that the clamp is opened.

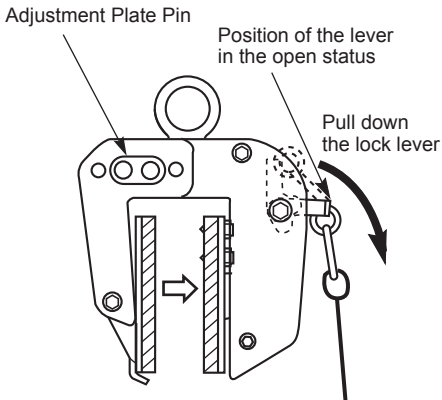

4. Under the open status of the clamp, insert the load all the way up to the upper end of the opening, and then pull up the lock lever. Then, you are ready to lift up the load.

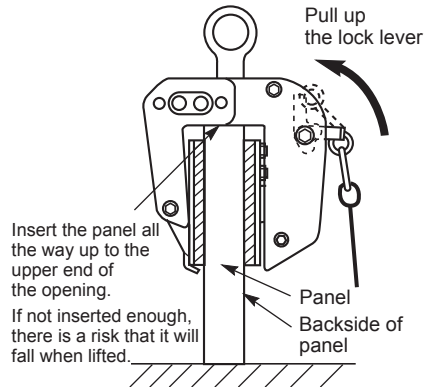

Note) Spike marring appears on the movable pad side, so please use the backside of the panel or other inconspicuous side.

- Confirm first that the lock lever is under the locked status, and then lift the crane and move the panel to a destination. In addition, use the balance (PSB) and lift the load at two points.

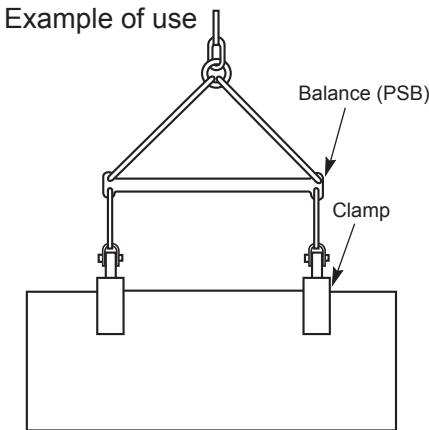
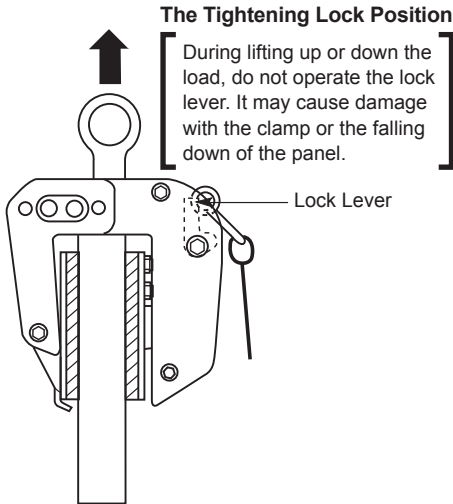

- After moving the load to a destination, lower the crane until you have confirmed that the panel is completely on the ground.

- When you have lowered the crane till the wire rope is loosened enough, pull down the lock lever to acquire the open status of the clamp. (If not pulled down enough, the clamp cannot be unlocked.) In addition, make the arrangements for the panel not to fall down or drop off (for the panel to be temporarily fixed) after the panel has landed, and then loosen the wire rope and pull down the lock lever to open the clamp.

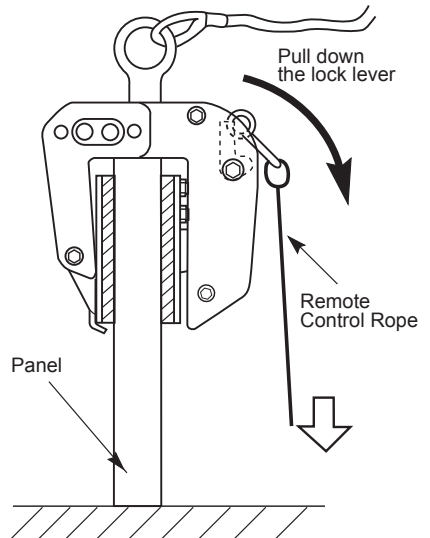

- If you move to the next operation, start with No. 3 of the procedure after confirming the clamping range and capacity required.



9. When the remote control is found impossible because of some obstacles on the backside of the panel, replace the movable pad with a fixed pad, and then clamp the panel with the front side of the panel directed toward the originally movable-pad side. If you proceed this way, you can control the operation by using the remote control rope without damaging the surface of the front side of the panel. (Refer to the figure below.) In addition, if spikes are simultaneously fixed on both of the pads, the clamp range will differ from the product feature displayed, and it will be harder to remove the panel from the clamp.

The spare holes for fixing spikes are arranged in advance for PSC 100 and PTC 150/250, so if the spikes are not effective enough to grip the panel when it is clamped, replace the positions of the spikes using the spare holes as shown in the figure below.

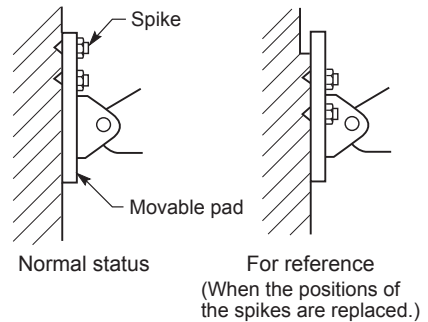

When a spike is applied to the front surface of the load, a spike marring is applied to the surface.

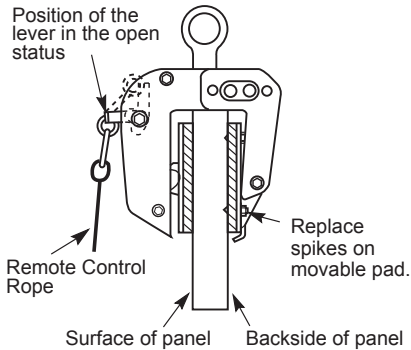



## WARNING

### ■ Operation Precautions

1. When lifting the load, all personnel must be clear of the area of operation to prevent falling accidents, etc.
2. Never use for the load beyond the clamp range. Confirm the dimensions of thickness of the panel, and be sure to set the adjustment plate pin on the position of clamp range.  
(Refer to No. 2 of “how to use” on Page. 13.)
3. Confirm the weight of the load. Do not exceed maximum capacity of the clamp.
4. Set and lift the load at the horizontal center of gravity as shown in the figure below. Use two clamps and balance (PSB) when lifting.

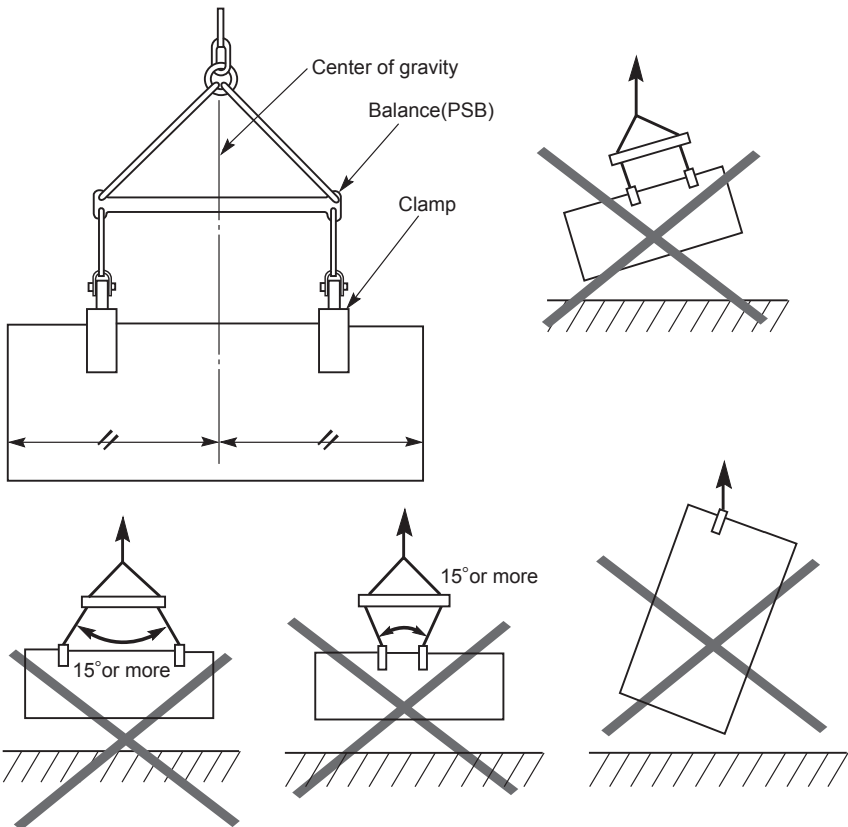

5. Never lift two or more panels at a time. It may cause a falling accident of the panels. Be sure to lift only one panel at a time.

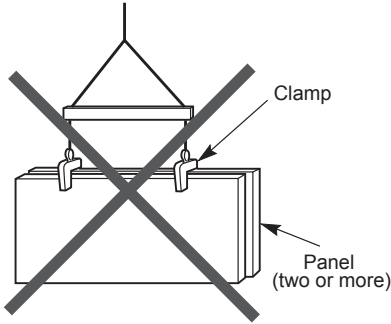

6. This clamp is dedicated for vertical lifting, not for lateral lifting of panel. Side grabbing of panel is strictly prohibited. It is dangerous because the clamp's tightening force does not work.

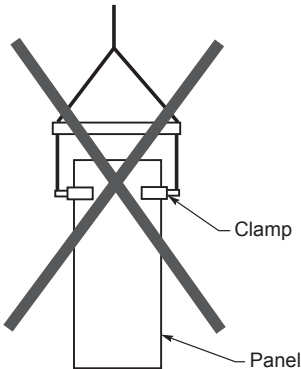
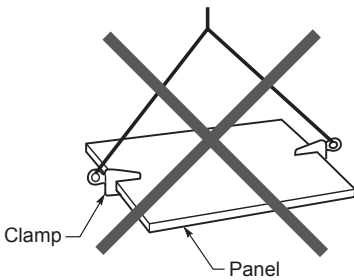

7. When lifting, special attention must be given to prevent unintended contact with any other objects. (Be especially careful during lifting and lowering operations.) A shock or loosening of the rope may cause a falling accident.

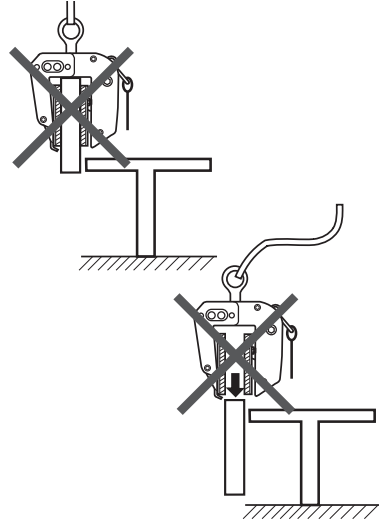

8. Take specially care that the remote control rope does not get caught on scaffolding or other obstacles during lifting and lowering operations.

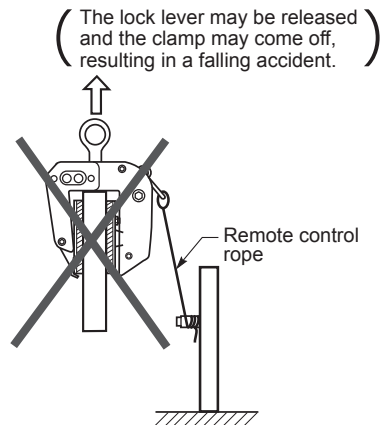

9. Do not use the clamp with the pad or panel (lifting load) attached with water, ice, snow, oil, sands, mud, etc.

10. Keep the height of the protrusion of the spikes on the movable-pad side between 1.5 and 2mm.

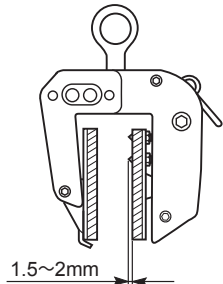

11. Be sure to confirm that the surface of panel is securely adjusted by both of the pads of the clamp.

PTC100 : 25mm or less  
 PTC150·250 : 60mm or less  
 PSC100 : 50mm or less



PTC100 : 80mm or more  
 PTC150·250 : 125mm or more  
 PSC100 : 115mm or more

Fixed pad

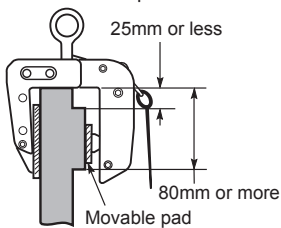

In case of PTC100



In case of PTC150, 200 and 250

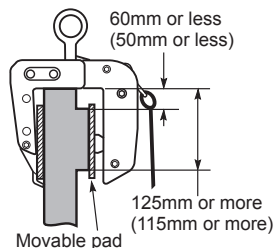

( ) is the value of PSC100.

In addition, the following clamping statuses may cause dangers as shown in the figure below. The pads of the clamp may be damaged or deformed, and a panel falling accident may be caused.

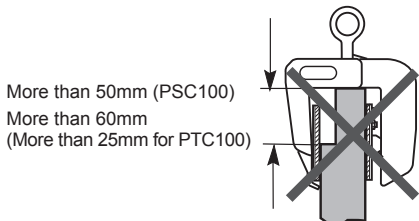
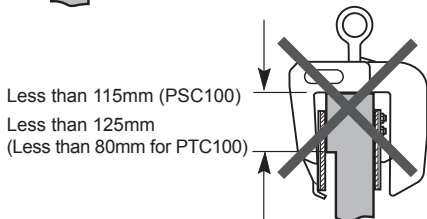
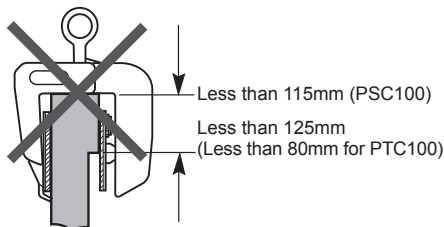
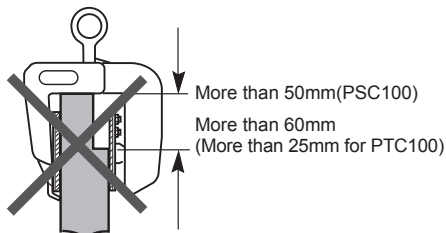
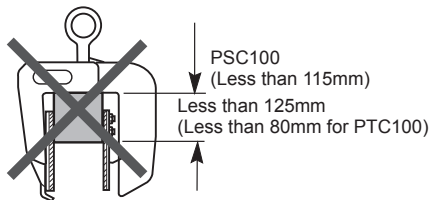

12. Never alter the clamp by user's own, applying heating or welding. Heating, modifying, etc. will significantly reduce the quality (strength).

13. Put the lock lever into the locked status after having clamped the panel. And be careful enough not to catch your hand or fingers between the lock lever and the clamp.

14. When you pull up the panel, install the clamp with the lock lever side up.

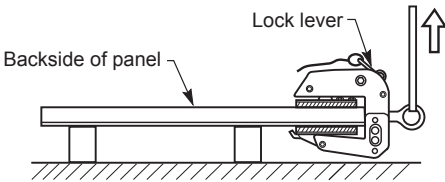

Do not pull out a panel out of the piled panels from the middle.

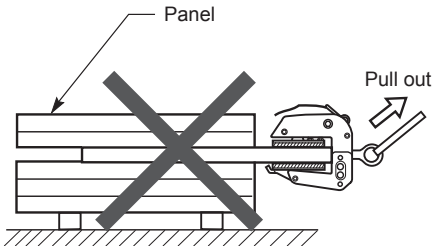

15. When setting panels with interior and exterior wall panels attached to the upper frame, make sure that the upper frame is in the surface where the pads of the clamps hit.

Gripping where the upper frame is not in may cause the panel to break or fall.

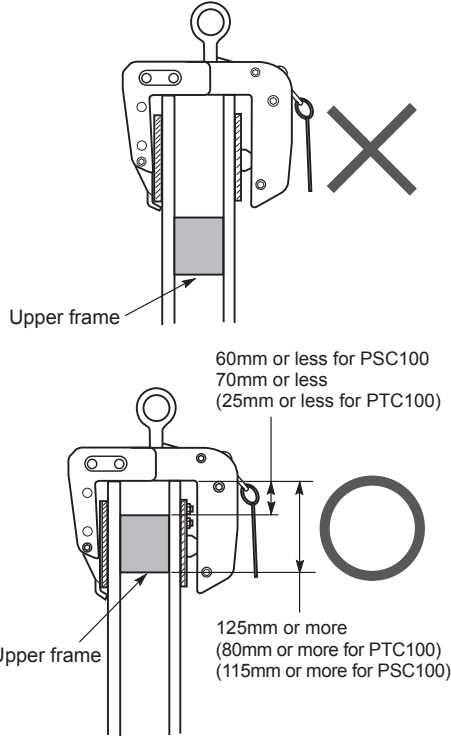

16. Do not use the clamp on panels which spikes cannot bite, such as metal panels or tiles, on both sides or on one side of the panel.

17. Conduct daily inspection and maintenance by referring to inspection standards to check to find any abnormalities of the movement of each parts.



## CAUTION

### ■ Maintenance and Inspection

#### 1. Maintenance

Daily maintenance is important for efficient and safe operation even under the severe use condition and for such purposes. Please comply with the followings.

- (1) Designate the inspection standards and control.
- (2) Keep clamps indoor and do not leave them outdoor.
- (3) Check the followings to maintain in a good condition.
  - (a) Operating condition.
  - (b) Wear of pads and spikes.
  - (c) Deformation of main body.
- (4) Separate conforming clamps and other hazardous items identified during use or inspection and designate the defective sections. Perform maintenance any soon.
- (5) Perform inspection and maintenance once a week by referring to inspection standards.
- (6) Lubricate sliding sections such as bolts and pins periodically. However, be careful not to put oil on the surface of the polyurethane rubber of the pad.

#### 2. Periodic Inspection

Perform periodic inspection in accordance with the periodic inspection and maintenance standards. Functions and life of clamps may differ in a great degree as they are used in varieties of fields under different conditions of use. Therefore, preparation and practice of effective operation/inspection standards manual by users themselves are recommended.

We ask you to establish complete maintenance and control for assurance of safety in reference to our inspection standards of our clamp. For your preparation of the standards, pay special attention to the followings.

- (1) Operation and maintenance standards
  - (A) Preparation of use criteria (shape of load and operating methods).

- (B) Thorough understanding and compliance of cautions on handling.
  - (C) Rules of inspection and check at site.
- (2) Standards on periodic inspection
  - (A) Establishing dates of periodic inspection.
  - (B) Establishing inspection and maintenance methods.
    - (a) Inspecting period.
    - (b) Person in charge of the inspection.
  - (c) Inspection site.
  - (d) Tools and devices for inspection.
  - (e) Establishment of permissible limit of use.
  - (f) Explicit designation of maintenance and repair methods.

#### 3. Manufacturer's inspection method

Our company's inspection procedures are as follow.

Check for



- (1) Deformation, wear, dirt or damage of pads.
- (2) Wear, rattle, loss of spikes.
- (3) Wear of spikes.
- (4) Deformation of main body.
- (5) Deformation of shackle.
- (6) Defects of bolts, pins, links, and springs.



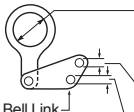

#### ■ Daily Inspection

Conduct daily checks and maintenance to prevent the loss of safety and efficiency.

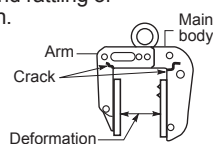
1. Check that there are no cracks or damage at each parts of the main body, pad and shackle.
2. Check if bolts, nuts and pins are installed securely.
3. Check if the movement and lubrication condition of each part are good.
4. Check that there are no deformation, wear or loss of pad.
5. Check that there are no wear or loss of spike.
6. Check that pad is not dirty.
7. Refer to inspection standards.

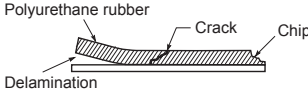
# INSPECTION STANDARDS FOR PTC, PSC

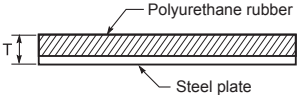
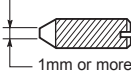
Item	Inspection method	Limit of use	Causes	Remedy																																				
<b>Shackle</b>	Check for deformation of holes.	<p>When the degree of deformation of shackle hole exceeds more than 1mm, and the degree of deformation of pin hole exceeds 0.5mm.</p> <table border="1"> <thead> <tr> <th>Size</th> <th>Standard</th> <th>Limit</th> </tr> </thead> <tbody> <tr> <td>250</td> <td>50</td> <td>51</td> </tr> <tr> <td>200-150</td> <td>40</td> <td>41</td> </tr> <tr> <td>100</td> <td>26</td> <td>27</td> </tr> </tbody> </table>  <table border="1"> <thead> <tr> <th>Size</th> <th>Standard</th> <th>Limit</th> </tr> </thead> <tbody> <tr> <td>250</td> <td>10.2</td> <td>10.7</td> </tr> <tr> <td>200-150</td> <td>8.2</td> <td>8.7</td> </tr> <tr> <td>100</td> <td>6.2</td> <td>6.7</td> </tr> </tbody> </table> <table border="1"> <thead> <tr> <th>Size</th> <th>Standard</th> <th>Limit</th> </tr> </thead> <tbody> <tr> <td>250</td> <td>8.3</td> <td>8.8</td> </tr> <tr> <td>200-150</td> <td>8.2</td> <td>8.7</td> </tr> <tr> <td>100</td> <td>6.2</td> <td>6.7</td> </tr> </tbody> </table>	Size	Standard	Limit	250	50	51	200-150	40	41	100	26	27	Size	Standard	Limit	250	10.2	10.7	200-150	8.2	8.7	100	6.2	6.7	Size	Standard	Limit	250	8.3	8.8	200-150	8.2	8.7	100	6.2	6.7	<p>Overload</p> <p>Sudden shock load</p> <p>Impossible lifting angle</p>	Replace
	Size	Standard	Limit																																					
250	50	51																																						
200-150	40	41																																						
100	26	27																																						
Size	Standard	Limit																																						
250	10.2	10.7																																						
200-150	8.2	8.7																																						
100	6.2	6.7																																						
Size	Standard	Limit																																						
250	8.3	8.8																																						
200-150	8.2	8.7																																						
100	6.2	6.7																																						
Visually check or measure to find vending or deformation.	<p>When the degree of bending or deformation exceeds 5°.</p> 																																							
<b>Main body, Arm</b>	Check for cracks or deformation.	<p>When found cracks or deformation visually.</p>	<p>Overload</p> <p>Shock of falling</p> <p>Sudden shock load</p> <p>Impossible lifting angle</p>	<p>Discard of main body</p> <p>Replace of arm</p>																																				
	Visually check for rattling of locking pin.	<p>When found rattling of locking pin.</p>  <p>At each set position of the adjustment plate pin (refer to Page. 13), when the main body and arm are fully extended with the movable pad open, the parallel dimension between the pads on both sides is larger than the maximum clamp range to the limit dimension in the table below.</p> <table border="1"> <thead> <tr> <th>Item No.</th> <th>Limit dimensions of deformation of main body and arm (mm)</th> </tr> </thead> <tbody> <tr> <td>PTC100</td> <td>4 or more</td> </tr> <tr> <td>PSC100 · PTC150</td> <td>8 or more</td> </tr> <tr> <td>PTC200</td> <td>8 or more</td> </tr> <tr> <td>PTC250</td> <td>8.5 or more</td> </tr> </tbody> </table>			Item No.	Limit dimensions of deformation of main body and arm (mm)	PTC100	4 or more	PSC100 · PTC150	8 or more	PTC200	8 or more	PTC250	8.5 or more																										
Item No.	Limit dimensions of deformation of main body and arm (mm)																																							
PTC100	4 or more																																							
PSC100 · PTC150	8 or more																																							
PTC200	8 or more																																							
PTC250	8.5 or more																																							

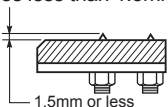
Item	Inspection method	Limit of use	Causes	Remedy																	
Pad	Visually check for cracks, chips and delamination of polyurethane rubber.	When visually found cracks, chips and delamination. 	Overload Use on other than pad flat surfaces. Others	Replace																	
	Visually check or measure deformation of pad.	When found more than 0.5mm bending or deformation. 	Overload Sudden shock load Impossible lifting angle	Replace																	
	Visually check or measure for wear of polyurethane rubber.	When the thickness of pad becomes smaller than the respective size in the table below. <table border="1" data-bbox="437 600 745 708"> <thead> <tr> <th rowspan="2">Item No.</th> <th colspan="2">Limit dimensions of use (T)</th> </tr> <tr> <th>Movable pad</th> <th>Fixed pad</th> </tr> </thead> <tbody> <tr> <td>PTC100</td> <td>8mm or less</td> <td>6mm or less</td> </tr> <tr> <td>PSC100 · PTC150</td> <td>8mm or less</td> <td>8mm or less</td> </tr> <tr> <td>PTC200</td> <td>8mm or less</td> <td>8mm or less</td> </tr> <tr> <td>PTC250</td> <td>9mm or less</td> <td>9mm or less</td> </tr> </tbody> </table> 	Item No.	Limit dimensions of use (T)		Movable pad	Fixed pad	PTC100	8mm or less	6mm or less	PSC100 · PTC150	8mm or less	8mm or less	PTC200	8mm or less	8mm or less	PTC250	9mm or less	9mm or less	Natural wear or others	Replace
	Item No.	Limit dimensions of use (T)																			
		Movable pad	Fixed pad																		
	PTC100	8mm or less	6mm or less																		
	PSC100 · PTC150	8mm or less	8mm or less																		
PTC200	8mm or less	8mm or less																			
PTC250	9mm or less	9mm or less																			
Visually check or measure for wear or cracks of spike.	When the wear degree of the flat surface of tip exceeds 1mm.  When found crack of tip. 	Natural wear or others Lifting of hard objects, such as steel, concrete and stone.	Replace																		
Visually check or measure if the tip of spike is appropriate.	When protrusion of spike becomes less than 1.5mm. 	Natural wear or others Looseness of installing nut	Tightening adjustment																		
Visually check that the pad adjusting screws are not loose or do not fall off.	When found looseness or rattling of screws.	Sudden shock load Impossible lifting angle	Tightening adjustment																		
	When found falling off of screws (bolt and nut).	Failure to handle or inspect, or others.	New Installation																		

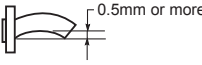
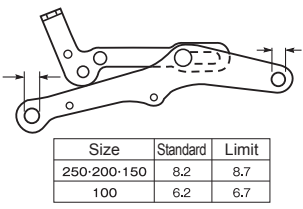
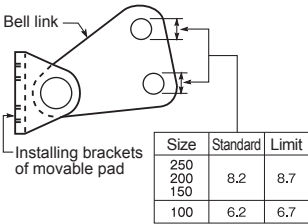

Item	Inspection method	Limit of use	Causes	Remedy									
<b>Adjustment Plate Pin</b>	<p>Visually check or measure to find bending or deformation of the pin.</p> <p>Visually check or measure to find cracks or damage.</p>	<p>When found more than 0.5mm bending or deformation.</p> <p>When found cracks, falling off of spring pin or damage.</p> 	<p>Overload</p> <p>Sudden shock load</p> <p>Impossible lifting angle</p>	Replace									
<b>Lock Lever Link</b>	<p>Visually check or measure to find deformation of pin hole or link, etc.</p> <p>Visually check if the movement of the lock lever is smooth.</p>	<p>When pin holes are stretched or bent more than 0.5 mm.</p>  <table border="1" data-bbox="448 574 666 646"> <thead> <tr> <th>Size</th> <th>Standard</th> <th>Limit</th> </tr> </thead> <tbody> <tr> <td>250-200-150</td> <td>8.2</td> <td>8.7</td> </tr> <tr> <td>100</td> <td>6.2</td> <td>6.7</td> </tr> </tbody> </table> <p>When the movement or operation of the lock lever is not smooth because of bending or deformation of link, etc.</p>	Size	Standard	Limit	250-200-150	8.2	8.7	100	6.2	6.7	<p>Overload</p> <p>Sudden shock load</p> <p>Impossible lifting angle</p>	Replace
Size	Standard	Limit											
250-200-150	8.2	8.7											
100	6.2	6.7											
<b>Cam</b>	<p>Visually check or measure to find deformation of pin hole, etc.</p> <p>Visually check if the movement of movable pad of installing bracket is smooth.</p>	<p>When pin holes are stretched more than 0.5 mm.</p>  <table border="1" data-bbox="548 957 705 1053"> <thead> <tr> <th>Size</th> <th>Standard</th> <th>Limit</th> </tr> </thead> <tbody> <tr> <td>250 200 150</td> <td>8.2</td> <td>8.7</td> </tr> <tr> <td>100</td> <td>6.2</td> <td>6.7</td> </tr> </tbody> </table> <p>When the movement of the installing brackets of movable pad or bell link is not smooth because of deformation etc. of installing brackets or link.</p>	Size	Standard	Limit	250 200 150	8.2	8.7	100	6.2	6.7	<p>Overload</p> <p>Sudden shock load</p> <p>Impossible lifting angle</p> <p>Insufficient lubrication or others</p>	Replace
Size	Standard	Limit											
250 200 150	8.2	8.7											
100	6.2	6.7											

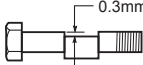
Item	Inspection method	Limit of use	Causes	Remedy
<b>Bolt, Nut</b>	Visually check or measure to find the wear or deformation of shaft part.	When found more than 0.5mm bending or deformation.  When found more than 0.3mm step or wear of shaft part. 	Overload Sudden shock load Impossible lifting angle	Replace
	Visually check to find looseness of bolts or nuts.	When found looseness or missing of bolts, nuts and etc.	Sudden shock load Long-term use or others	Replace or adjust
<b>Spring</b>	Visually check for appropriate repulsive force when the lock is applied and the shackle is pressed.	When the shackle is pushed down and there is no repulsive force of spring. When visually found bending or breakage of spring.	Overload Sudden shock load Fatigue or others	Replace