

NOTES : UNLESS OTHERWISE SPECIFIED

1. ALL DIMENSIONS ARE IN MILLIMETERS. \triangle
2. TO PREVENT IRREGULAR WINDING OF THE WIRE ROPE AROUND THE DRUM, KEEP THE FLEET ANGLE 2 DEGREES OR LESS. PLEASE INSTALL THE PULLEY 800mm OR MORE AWAY FROM THE DRUM ON THE CENTER LINE OF THE DRUM.
3. THE VALUE OF SPECIFIED "WIREROPE TENSION" ON THIS DRAWING IS FOR THE STANDARD LAYER OR LESS. THE VALUE OF THE "WIRE ROPETENSION" MUST BE DECREASED ACCORDANCE WITH THE RATIO OF THE ACTUAL WINDING LAYERS, IF IT EXCEEDED.

Specifications			(The wire rope composition is a manufacturer recommendation.)	
Load Rating	2,940N (= 300kgf)	Handle Force	Handle Length	Number of Wire Rope Winding Layer
Wire Rope Tension	5th Layer (Standard Layer)		250mm	
Drum Capacity	Wire Rope 6-Layer Windings ϕ 6mm (6 x 37), JIS x 32m		Wire Rope Tension	3rd Layer 103N (= 10.5kgf)
Gear Ratio	1/6.25	Standard Accesories		5th Layer 131N (= 13.3kgf)
Effective Handle Length	250mm (Maximum)	Painting		One Handle
Weight	14.1kg (Winch + Handle)			One Hex Wrench for Anchoring the Wire Rope
				Melamine Resin Coating at Two Layers Painting Color Drum : Black (Munsell N1 Semi Gloss) Others : Munsell 7.5YR6/11

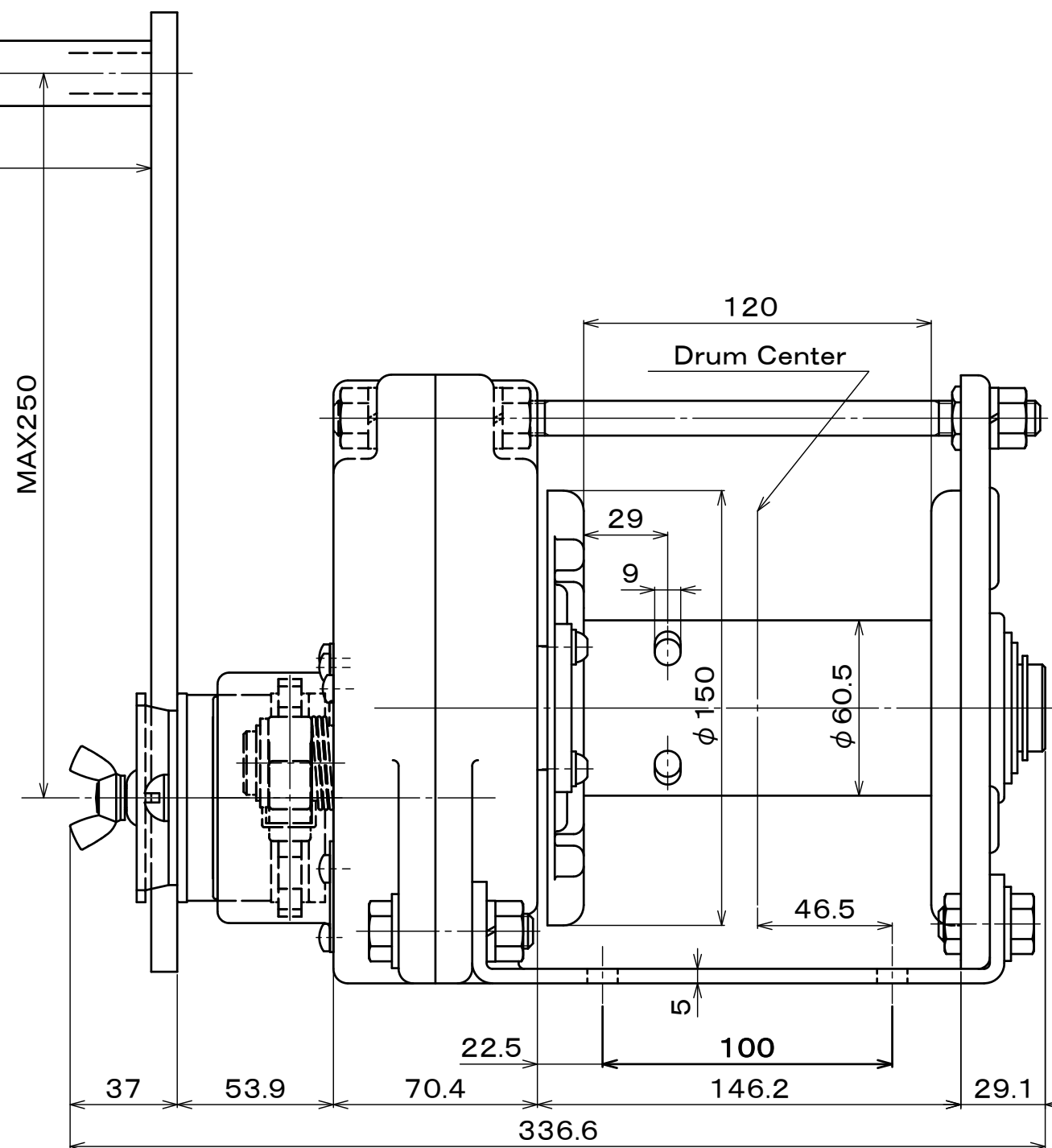
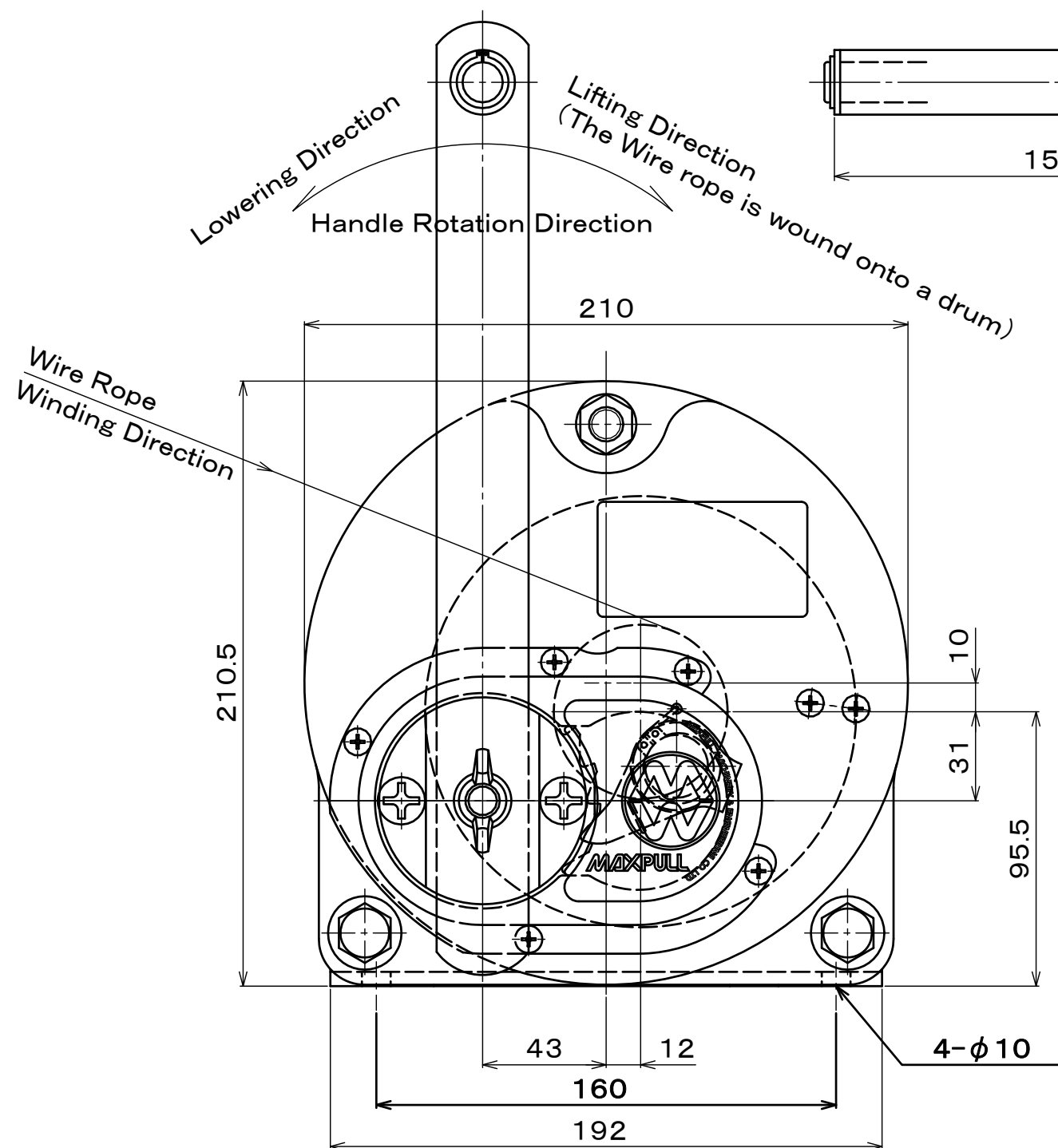

\triangle x			図面番号/DRAWING No.	改訂番号 REVISION No.	お客様/CUSTOMER	符号 MARK	項目 PARTICULARS	材料 MATERIAL	数量 QTY	単体 PER ONE	合計 TOTAL	備考 REMARKS
\triangle x	2023.12.04	Added transparent window to clutch cover.	GM3SI-160620-01E	03								
\triangle x	2022/08/22	Changed the Handle Arm	承認/APPROVED	検図/CHECKED	作成/DRAWN	図面名/TITLE	投影法/PROJECTION METHOD					
\triangle x 1	MAY 21, 2020	SPECIFIED UNITS	設計課 24.02.22 米澤	設計課 24.02.22 松嶺	設計課 24.02.22 平形	MAXPULL WINCH STOPPER ARMLESS ROTATING MODEL GM-3-SI	第三角法 THIRD ANGLE PROJECTION 尺度/SCALE 台数/QTY					
改訂/REVISION												

