



EW-3/5

Standard

FUNCTION

-  Plug type cable set
-  Ratchet system spring adjustment
-  CE Mark available

* Only EW-3 is available for CE Mark

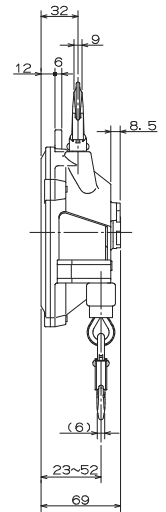
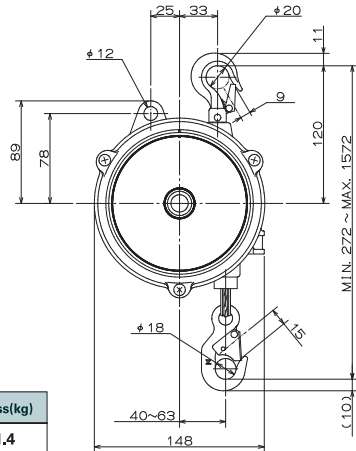

Model	Capacity(kg)	Travel(m)	Cable dia(ϕ mm)	Mass(kg)
EW-3	1.0-3.0	1.3	3.0	1.4
EW-5	2.5-5.0	1.3	3.0	1.5

EWS-3/5/7

Standard

FUNCTION

-  Plug type cable set
-  Fall arrest device
-  Drum lock device
-  Worm gear spring adjustment
-  CE Mark available

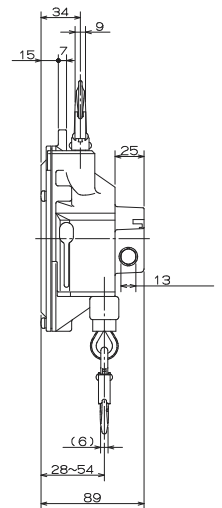
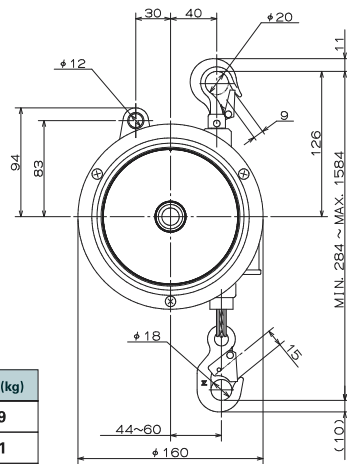

Model	Capacity(kg)	Travel(m)	Cable dia(ϕ mm)	Mass(kg)
EWS-3	1.5-3.0	1.3	3.0	1.9
EWS-5	3.0-5.0	1.3	3.0	2.1
EWS-7	5.0-7.0	1.3	3.0	2.1

EWF-9/15

Standard

FUNCTION

-  Gauge
-  Cartridge spring assembly
-  Plug type cable set
-  Fall arrest device
-  Drum lock device
-  Worm gear spring adjustment
-  CE Mark available

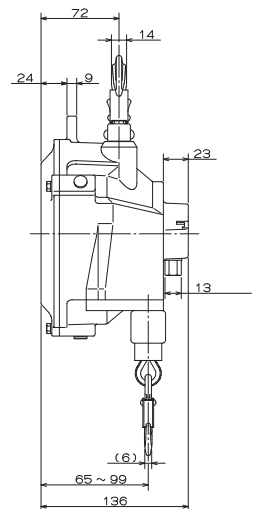
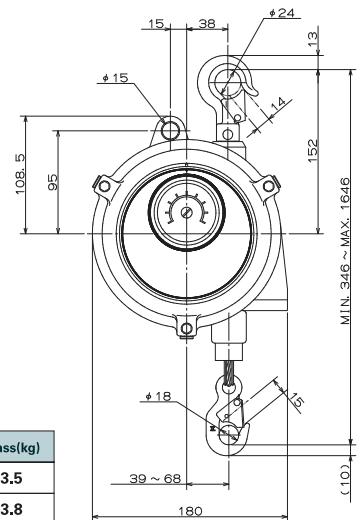

Model	Capacity(kg)	Travel(m)	Cable dia(ϕ mm)	Mass(kg)
EWF-9	4.5- 9.0	1.3	4.0	3.5
EWF-15	9.0-15.0	1.3	4.0	3.8

Selection of suitable model

Always use a suitable model meeting the total weight of suspended tool or instrument. The balancer should be selected considering the weight of the tool and accessories.

Installation

- Install Spring balancers uneven not to hit each other when the balancers are installed in a line.
- Always employ a secondary support chain and leave the slack for smooth swivel.
- Always adjust the spring tension to meet the total weight of tool and the application.