

EHW-60R , EHW-120R

FUNCTION



Wire rope type



Button control



Plain trolley (on request)



Emergency stop button (on request)

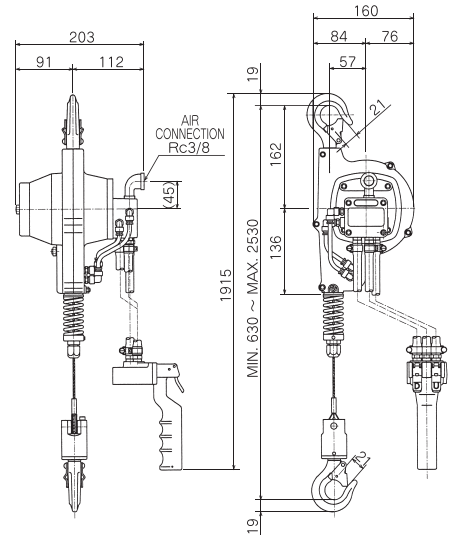

*The Length of control hose is 1.5m.

Model	Rated load (kg)	Stroke (m)	Air pressure MPa (kgf/cm ²)	Lifting speed m/min	Air consumption m ³ /min (normal)	Air inlet	Mass (kg)
EHW-60R	60	1.9	0.4 {4}	18.5	0.55	Rc 3/8	9.5
			0.5 {5}	22.5	0.7		
			0.6 {6}	26.0	0.88		
EHW-120R	120		0.4 {4}	11.0	0.59		9.7
			0.5 {5}	13.5	0.75		
			0.6 {6}	16.0	0.93		

Note

1. Install a filter and lubricator to the hoist as close as possible.
2. Both of cable extension and stroke extension are not available on EHW series and AH-250R.
3. Chain hoists are recommended for the frequent operation.
4. Application; Indoor -10°C~+50°C (Temperature)