

EHL-05TS

EHL-05TS

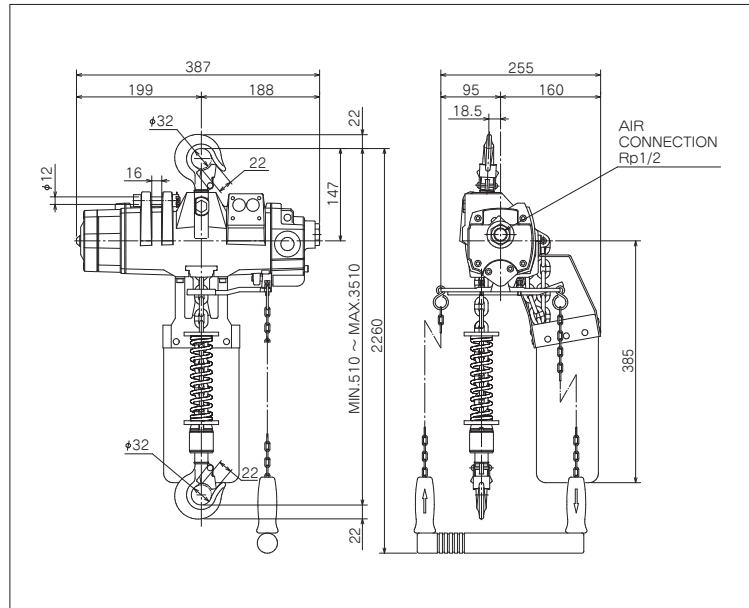

*The length of control chain is 2m.

EHL-05TS PCS-1

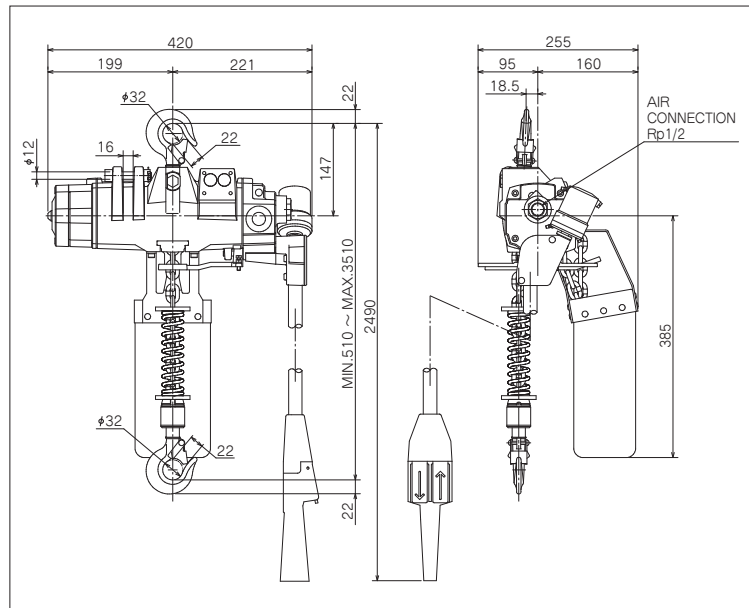

*The Length of control tube is 2m.

FUNCTION



Chain type



Pendant control switch (on request)



Chain extension (on request)



Air motor trolley (on request)



Overload protector (on request)

Model	Rated load (kg)	Stroke (m)	Air pressure MPa (kgf/cm ²)	Lifting speed m/min	Air consumption m ³ /min (normal)	Chain size x fall	Air inlet	Mass (kg)
EHL-05TS	500	3	0.4 {4}	7.5	0.95	6.3x1	Rp 1/2	20.0
EHL-05TS PCS-1			0.5 {5}	9.0	1.3			22.0
			0.6 {6}	10.5	1.65			

Note) The extension of control tube is available up to 6m (total 8m length).

Note

1. Install a filter and lubricator to the hoist as close as possible.
2. Application; Indoor -10°C~+50°C (Temperature)