

1 2 3 4 5 6 7 8 9 10

NO	DESCRIPTION	MATERIAL	Q'TY	SIZE	REMARK
1		-	-	-	

A  
B  
C  
D  
E  
F  
G  
H

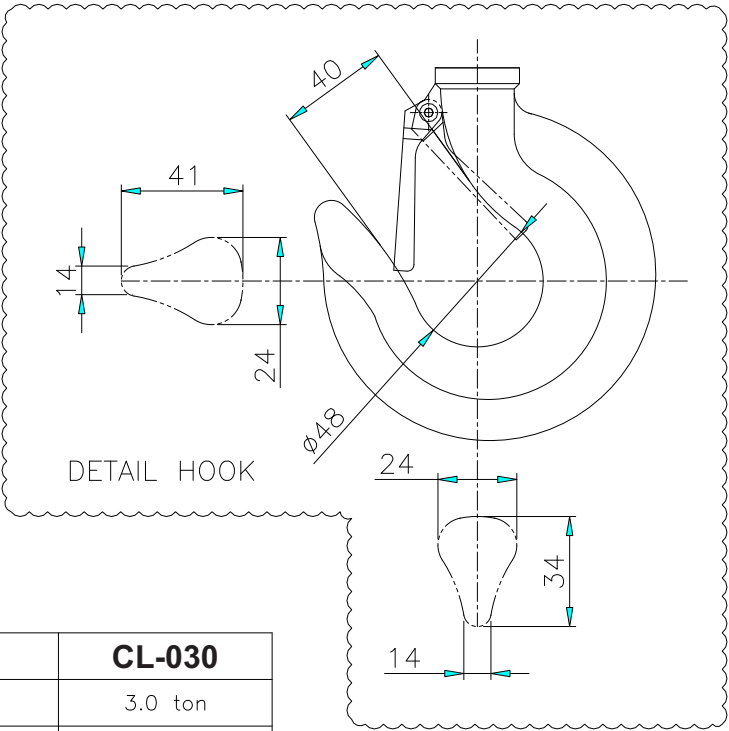
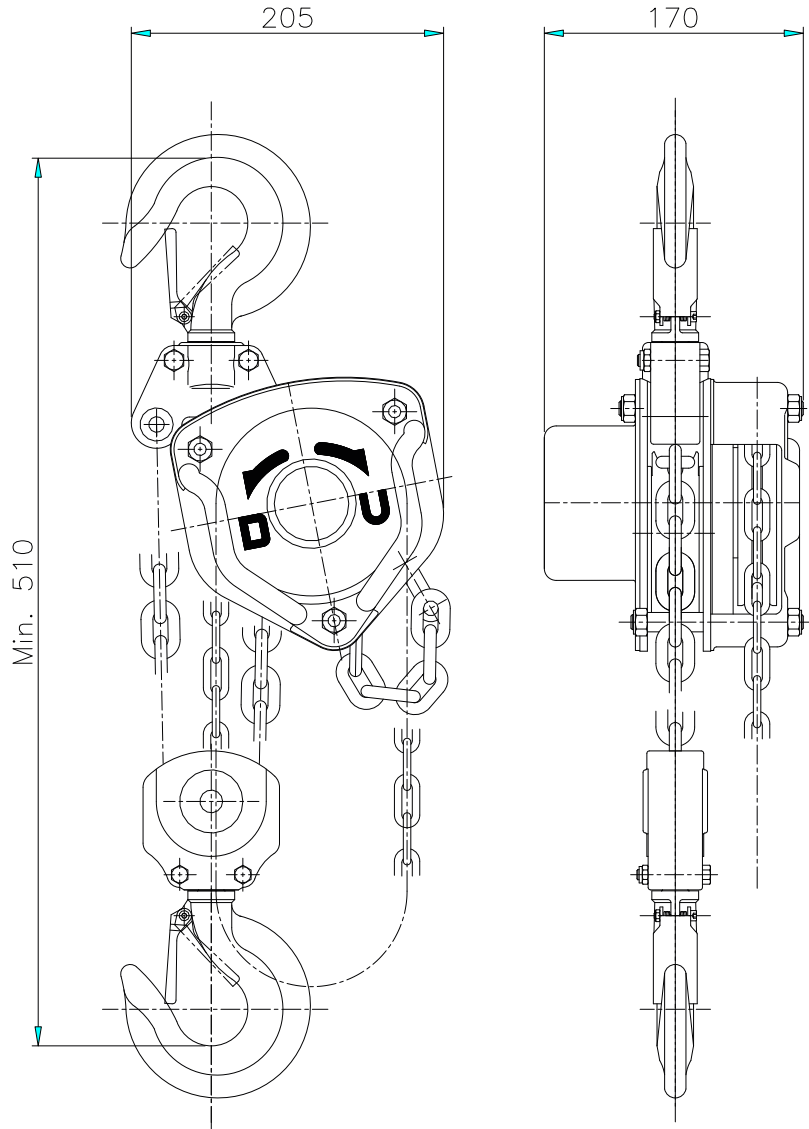

MODEL	<b>CL-030</b>
CAPACITY	3.0 ton
STANDARD LIFT	3.0 m
TEST LOAD	4.5 ton
PULLING EFFORT	35 kg
LOAD CHAIN	ø8x2 lines
HAND CHAIN	ø5x25 mm
NET WEIGHT	27 kg

REV	DATE	DESCRIPTION	DRAWN	CHECK	APPROV
PROJECT					
CLIENT					
MANUFACTURER					
TITLE ASSEMBLY DRAWING					
SCALE	DWG. NO.	SHT. NO.		REV.	
N/S					

1 2 3 4 5 6 7 8 9 10