

1 2 3 4 5 6 7 8 9

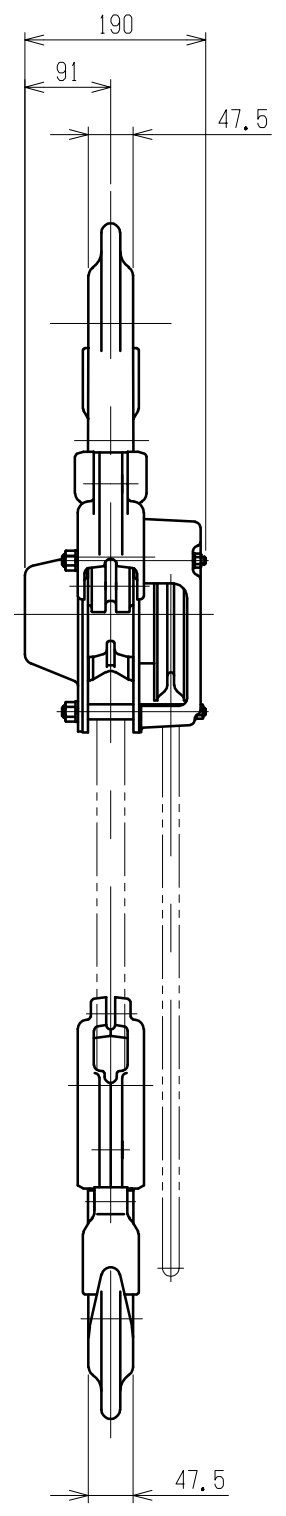
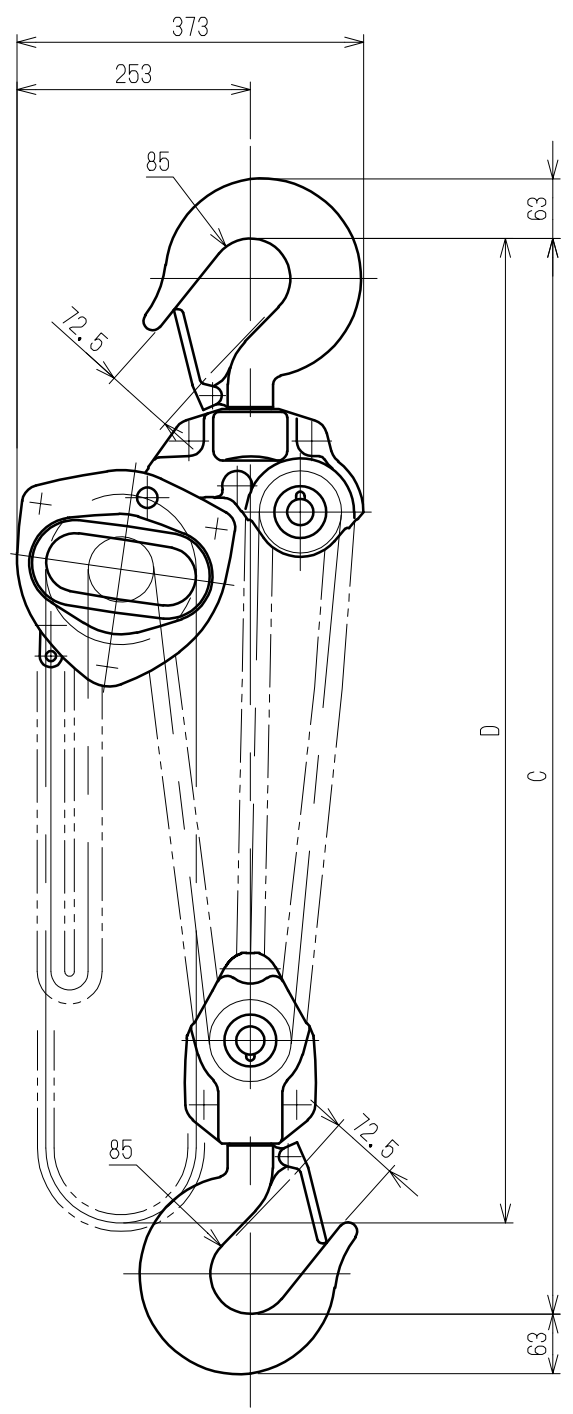

Specifications	
Working load limit	7 <sup>1</sup> / <sub>2</sub> T
Std. lift	3.5 m
Min. headroom :C	770 mm
Chain pull to lift full load	343 N (35 kgf)
Hand chain Length from top hook :D	4.2 m
Load chain size	9 x 27 mm
Mass	63 kg

Note;

						APPROVED	CHECKED	DESIGNED	DRAWN
						FUKASAWA	OKUYAMA	NAITO	NAITO
						2001. 10. 31	2001. 10. 31	2001. 10. 31	2001. 10. 31
1	-	Drawing update.		2023, 04, 06	T, Amemiya	S, Hagihara			
REV.	QTY	CONTENTS			DATE	DRAWN	APPROVED		



TITLE			
7.5t CB SERIES MANUAL CHAIN HOIST			
CODE	CB075	SCALE	1:8
DWG. NO.	C3BA075-12100	REV.	1