

1 2 3 4 5 6 7 8 9

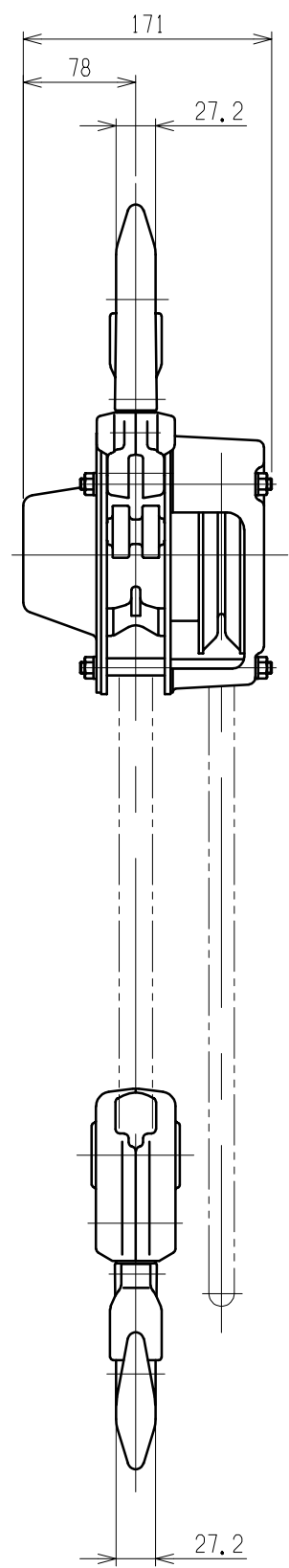
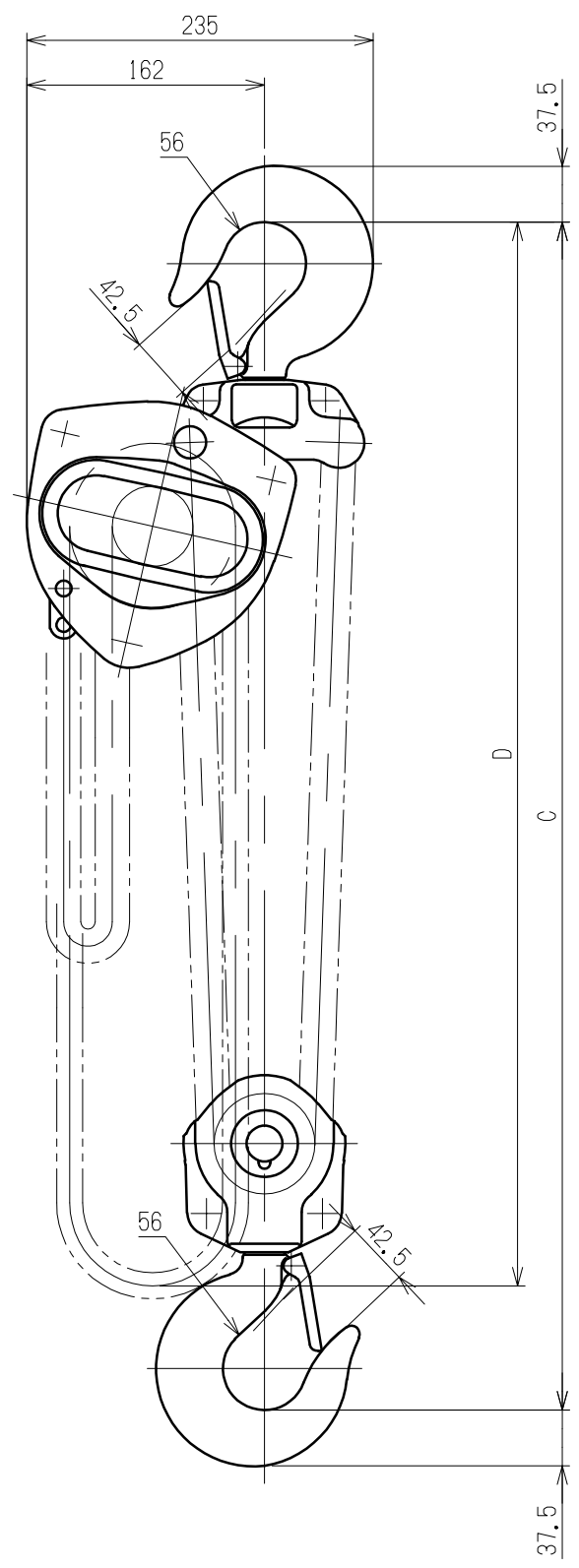

Specifications	
Working load limit	3 t
Std. lift	3.0 m
Min. headroom :C	510 mm
Chain pull to lift full load	353 N (36 kgf)
Hand chain Length from top hook :D	3.0 m
Load chain size	7.1 x 21 mm
Mass	24 kg

Note;

REV.	QTY	CONTENTS	DATE	DRAWN	APPROVED	APPROVED	CHECKED	DESIGNED	DRAWN
1	-	Drawing update.	2023, 04, 06	T. Amemiya	S. Hagihara	FUKASAWA	ARUGA	IINUMA	IINUMA
						2001. 4. 11	2001. 4. 11	2001. 4. 11	2001. 4. 11



TITLE			
3t CB SERIES MANUAL CHAIN HOIST			
CODE	CB030	SCALE	1:5
DWG. NO.	C3BA030-12100	REV.	1