

1 2 3 4 5 6 7 8 9

A
B
C
D
E
F

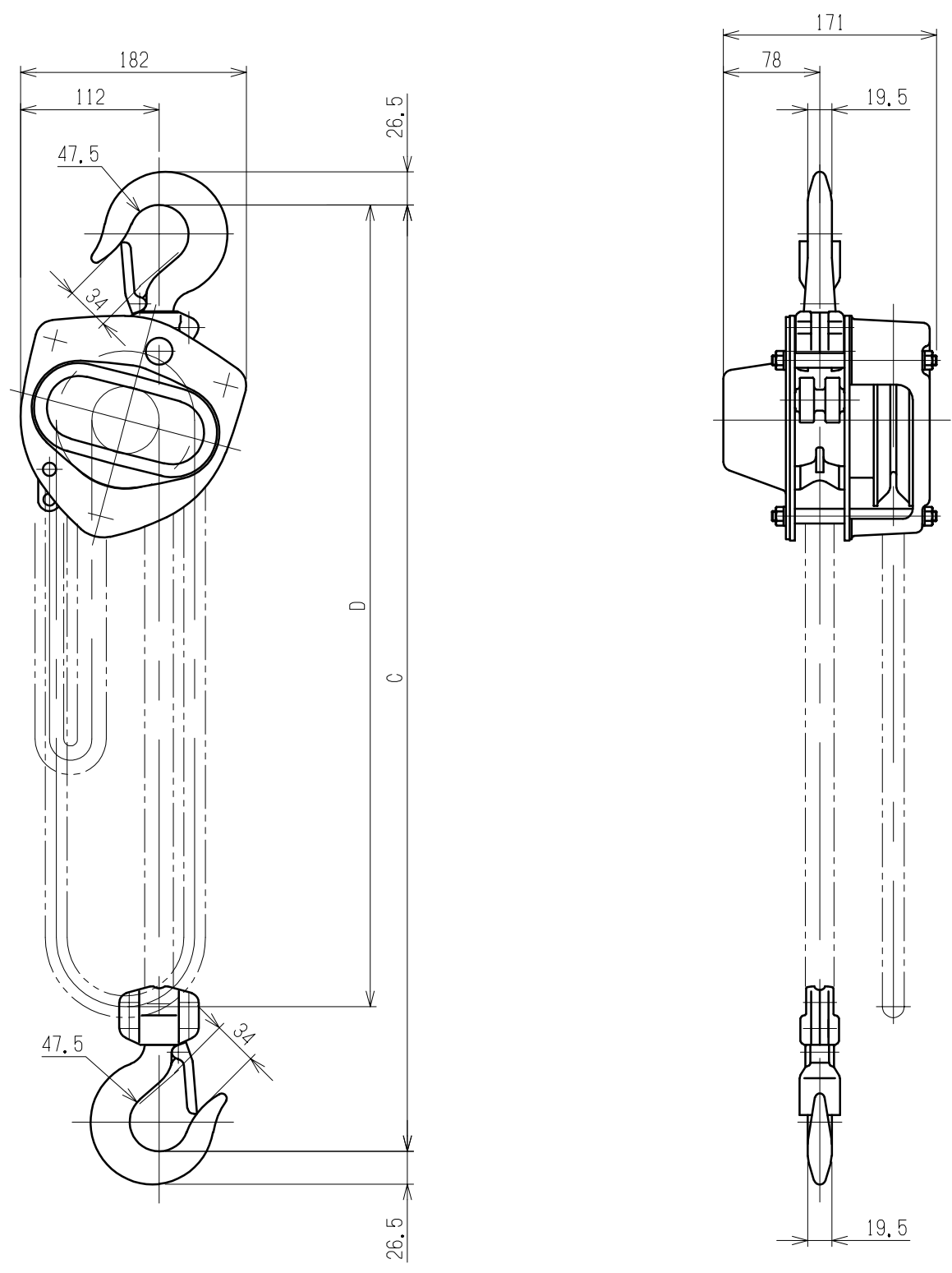

Specifications	
Working load limit	1.5 t
Std. lift	2.5 m
Min. headroom :C	350 mm
Chain pull to lift full load	343 N (35 kgf)
Hand chain Length from top hook :D	2.5 m
Load chain size	7.1 x 21 mm
Mass	14.5 kg

Note;

REV.	QTY	CONTENTS	DATE	DRAWN	APPROVED	APPROVED	CHECKED	DESIGNED	DRAWN	
1	-	Drawing update.	2023, 04, 06	T. Amemiya	S. Hagihara		SASAKI	OKUYAMA	ARUGA	ARUGA
							2000, 5, 25	2000, 5, 25	2000, 5, 25	2000, 5, 25



TITLE			
1.5t CB SERIES MANUAL CHAIN HOIST			
CODE	CB015	SCALE	1:5
DWG. NO.	C3BA015-12100	REV.	1