

FRENO LINKBOLT User Manual

Thank you for purchasing the FRENO LINKBOLT.

Please read this manual carefully before use and handle the FRENO LINKBOLT (hereafter referred to as FRENO), safely according to the instructions. Please keep this manual in a safe place.

Safety Precautions

- ① Do not apply a load higher than the working load limit (WLL).

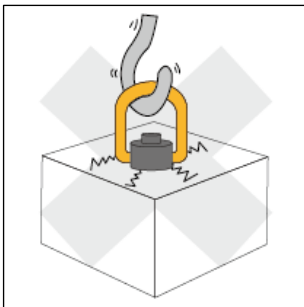

* Please refer to the WLL Table.

- ② Ensure FRENO is mounted evenly to the surface in close contact with the insert.

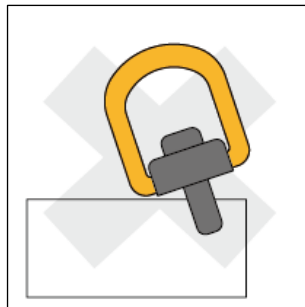

- ③ Avoid sudden uplifting from the ground (shock loading).

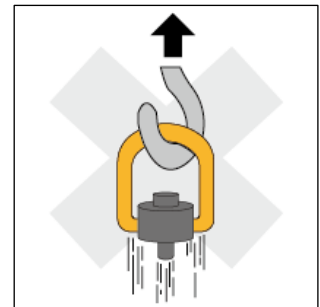

- ④ Do not directly connect hooks or fittings larger than the inner diameter of the link.

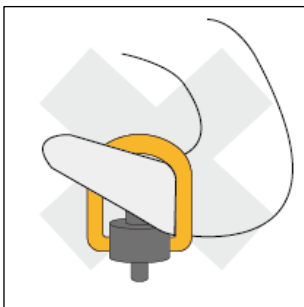

- ⑤ Do not use at an angle greater than 180 degrees to the mounting surface.

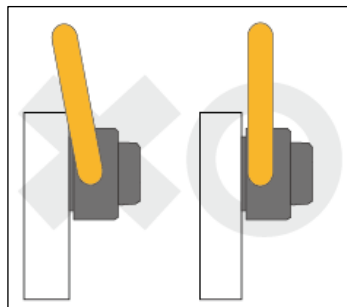

- ⑥ Tighten within the appropriate torque range.

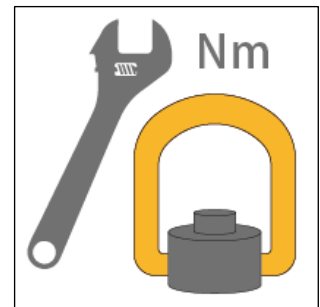

- ⑦ When using an impact wrench, be sure to use it within the appropriate torque range and do not press down too hard on the wrench.

Prohibitions

- Do not disassemble.
- Do not replace parts.
- Do not modify or perform additional processing.

FRENO LINKBOLT User Manual

Use

1. Confirm the lifting method and the load of the lifted object.
For the working load limit (WLL), refer to the comparison table on page 5.
2. Mount the FRENO onto the load you want to lift.

Mounting Method for A Type and B Type

- (1) Check the material of the load and the depth of the insert.

The hardness of the insert hole should be SS400, S25C or higher (Tensile strength 441N/mm²).

Ensure that the screw-in length (L dimension) is bolt diameter x 1.25 or longer.

When lifting cast iron or non-ferrous metals, the insert strength is low, the working load limit must be reduced.

- (2) Tighten with the appropriate torque for each FRENO size.
 - * Remove adhesives from the female thread before tightening.
 - * After mounting, make sure the link rotates smoothly.
 - * Ensure the FRENO seat fits tightly to the load (without gap).

When lifting secondary concrete products:

If there is a countersunk section on top of the insert metal fitting, use a washer with sufficient hardness and size to ensure a smooth mounting surface.

Please contact us for information on washer dimensions and WLL reduction rates.

Weld-on Method for C Type

- (1) Welding should be carried out by a trained welder.
- (2) Weld all around the base to achieve the specified leg length (a).
- (3) Use welding electrodes according to JIS standard D5016 LB-52A or similar.
- (4) In cold weather, preheat the welding surfaces before welding.
- (5) Inspect the weld for cracks.

3. Make sure no objects interfere with the rotation of the link.
4. Lifting operations should be carried out by qualified personnel only.

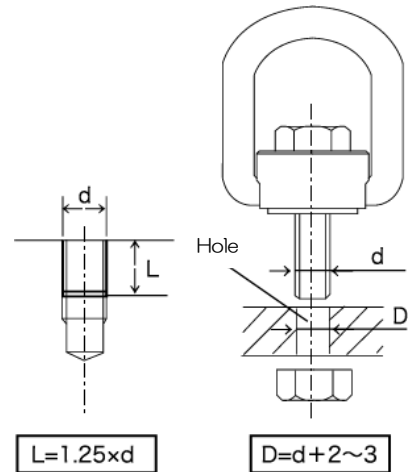

The nut material should be S45C or SCM435 or equivalent.

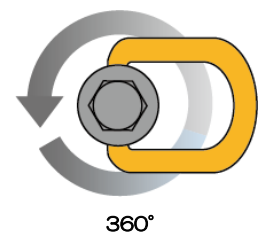
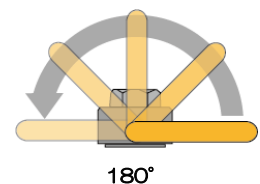
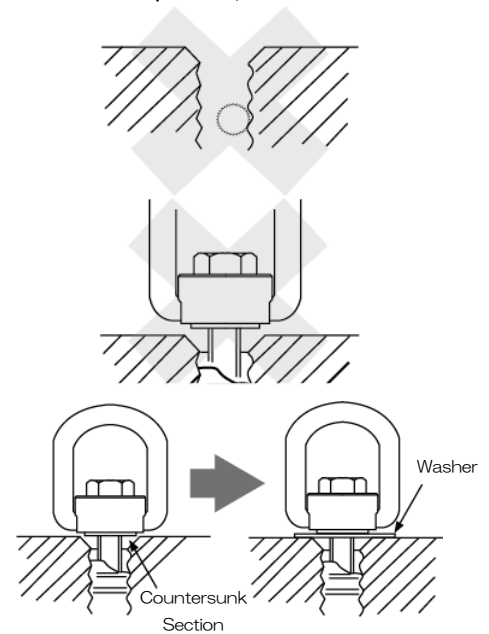

Please contact us if you request bolt diameter or length changes or if you have any questions regarding handling or use.

FRENO LINKBOLT User Manual

Inspection

1. Daily Inspection (Prior to Use)

Be sure to carry out the following checks before starting the lifting work.

- (1) Moveability: Once the FRENO is mounted, check if its link can be raised and lowered 180 degrees and the housing rotates smoothly.
- (2) Deformation: There should be no deformation of the link, no bending of the bolt, and the retaining ring should not be deformed or stand up.
- (3) Cracks: There should be no cracks. FRENO type C should show no loose welds or cracks at the welds.
- (4) There should be no abnormalities in the B and H dimensions.
* Tool for daily inspection available (see below).

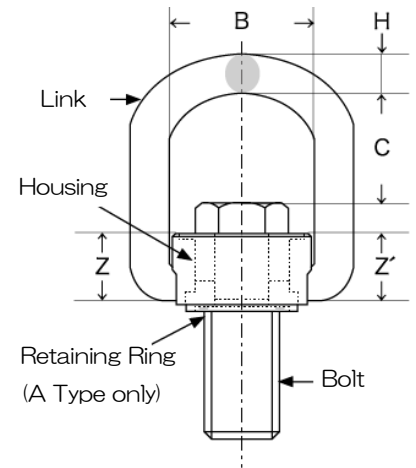

2. Periodic Inspection

Periodically measure wear and elongation as follows.

Set the inspection period depending on the frequency and environment of use.

- (1) Dimension H: Link wear should not exceed 5%.
- (2) Dimension B: Link widening/deformation should not exceed 5%.
- (3) Dimensions Z, Z' : Wear at the connection of link and housing should not exceed 5%.

Note: Since the link is a forged part and dimensional tolerances can occur, measure the initial dimensions before the first use.

We offer a (paid) inspection service. Please feel free to contact us.

Inspection Tool FRT (Optional Product)

H dimension (wear of link top))

B dimension (widening, deformation of link)

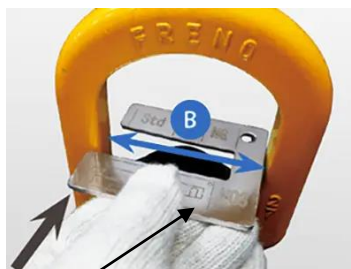
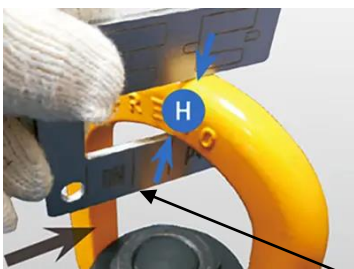

Inspection Tool FRT

FRENO LINKBOLT User Manual

Specifications

The working load limit (WLL) varies depending on the lifting method. Please refer to the WLL table.

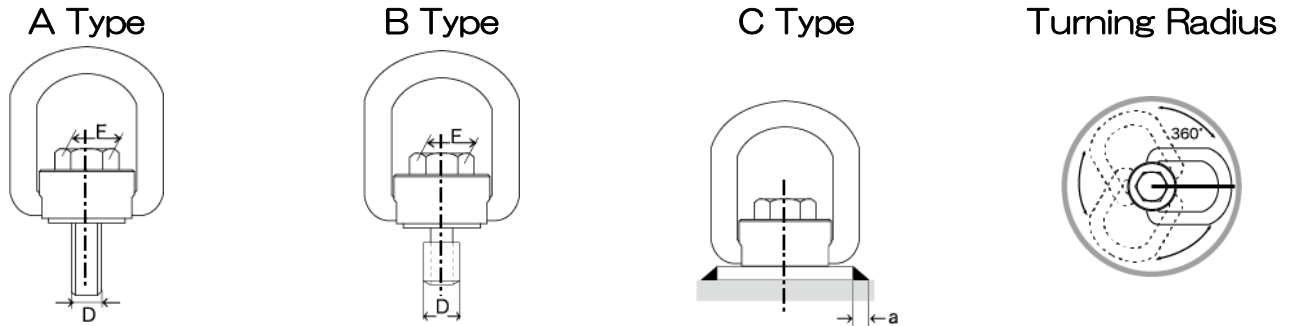



Product Code	WLL (t)	Bolt D	Hex. Width F (mm)	Tightening Torque (Nm)	Weight (kg)	Turning Radius (mm)
A-8	0.3	M8	13	8~15	0.25	63
A-10	0.5	M10	17	12~20	0.26	63
A-12	0.8	M12	19	18~29	0.81	101
A-14	1.2	M14	22	25~40	0.83	101
A-16	1.6	M16	24	30~49	0.85	101
A-18	2.3	M18	27	40~65	2.6	142
A-20	2.8	M20	30	49~78	2.6	142
A-22	3.1	M22	32	50~170	2.7	142
A-24	3.7	M24	36	59~196	2.7	142
A-27	5.0	M27	41	78~245	7.1	192
A-30	6.3	M30	46	108~	7.2	192
A-33	7.0	M33	50	150~	7.3	192
A-36	8.0	M36	55	177~	7.6	192
A-42	10.0	M42	65	230~	13.2	240
A-48	12.0	M48	75	294~	13.8	240
A-48L	15.0	M48	75	294~	15.6	245
A-12W	0.8	M12	19	18~29	0.82	101
A-16W	1.6	M16	24	30~49	0.85	101
A-20W	2.8	M20	30	49~78	2.6	142
A-24W	3.7	M24	36	59~196	2.7	142
A-30W	6.3	M30	46	108~	7.3	192
A-12S	0.8	M12	19	18~29	0.96	101
A-16S	1.4	M16	24	30~49	1.0	101
A-20S	2.6	M20	30	49~78	2.9	142
A-24S	3.7	M24	36	59~196	3.7	142
A-30S	6.0	M30	46	108~	8.1	192
A-36S	7.5	M36	55	177~	8.5	192
A-42S	10.0	M42	65	230~	10.0	240
A-48S	12.0	M48	75	294~	15.2	240

Product Code	WLL (t)	Bolt D	Hex. Width F (mm)	Tightening Torque (Nm)	Weight (kg)	Turning Radius (mm)
A-8E	0.3	M8	13	8~15	0.25	63
A-10E	0.5	M10	16	12~20	0.26	63
A-12E	0.8	M12	18	18~29	0.81	101
A-16E	1.6	M16	24	30~49	0.85	101
A-20E	2.8	M20	30	49~78	2.6	142
A-24E	3.7	M24	36	59~196	2.7	142
A-30E	6.3	M30	45	108~	7.2	192
A-36E	8	M36	54	177~	7.6	192
A-16K	1.6	M16	24	50	1.7	101
A-20K	2.8	M20	30	80	4.5	142
A-24K	3.7	M24	36	200	4.6	142
B-24	0.95	M24	30	18~29	0.95	101
B-30	1.5	M30	30	20~39	1.1	101
B-36	2.3	M36	46	34~49	3.1	142
B-42	3.4	M42	46	49~98	3.4	142
B-48	4.3	M48	46	59~147	3.7	142
B-64	9	M64	65	88~392	9.6	192
BB-64	15	M64	85	137~	17.4	245
B-80	15	M80	85	137~	19.2	245
B-100	15	M100	85	137~	23.1	245
MB-64	20	M64	85	196~	27.1	280
MB-80	20	M80	85	196~	29	280
MB-	20	M100	85	196~	32.7	280

Product Code	WLL (t)	Weld Leg Length (a)	Weight (kg)	Turning Radius (mm)
C-10	0.5	3	0.31	63
C-16	1.6	5	0.98	101
C-24	4	8	3.1	142
C-36	8	12	8.5	192

FRENO LINKBOLT User Manual

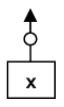
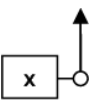
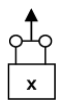
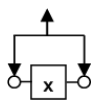
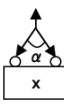
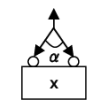
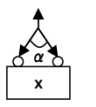
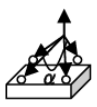
Table of Working Load Limits Depending on Lifting Method

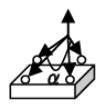
Lifting Method										
Lifting Angle (°)	0	90	0	90	$0 \leq \alpha \leq 60$	$60 < \alpha \leq 90$	$90 < \alpha \leq 120$	$0 \leq \alpha \leq 60$	$60 < \alpha \leq 90$	$90 < \alpha \leq 120$
Mode Coefficient	1	1	2	2	1.73	1.41	1	2.59	2.12	1.5
Product Code	Working Load Limit (t)									
A-8, A-8E	0,3	0,3	0,6	0,6	0,51	0,42	0,3	0,77	0,63	0,45
A-10, A-10E	0,5	0,5	1,0	1,0	0,86	0,7	0,5	1,2	1,0	0,75
A-12, A-12W, A-12S, A-12E	0,8	0,8	1,6	1,6	1,3	1,1	0,8	2,0	1,6	1,2
A-14	1,2	1,2	2,4	2,4	2,0	1,6	1,2	3,1	2,5	1,8
A-16S	1,4	1,4	2,8	2,8	2,4	1,9	1,4	3,6	2,9	2,1
A-16, A-16W, A-16E, A-16K	1,6	1,6	3,2	3,2	2,7	2,2	1,6	4,1	3,3	2,4
A-18	2,3	2,3	4,6	4,6	3,9	3,2	2,3	5,9	4,8	3,4
A-20S	2,6	2,6	5,2	5,2	4,4	3,6	2,6	6,7	5,5	3,9
A-20, A-20W, A-20E, A-20K	2,8	2,8	5,6	5,6	4,8	3,9	2,8	7,2	5,9	4,2
A-22	3,1	3,1	6,2	6,2	5,3	4,3	3,1	8,0	6,5	4,6
A-24, A-24W, A-24S, A-24E, A-24K	3,7	3,7	7,4	7,4	6,4	5,2	3,7	9,5	7,8	5,5
A-27	5,0	5,0	10	10	8,6	7,0	5,0	12,9	10,6	7,5
A-30S	6,0	6,0	12	12	10,3	8,4	6,0	15,5	12,7	9,0
A-30, A-30W, A-30E	6,3	6,3	12,6	12,6	10,8	8,8	6,3	16,3	13,3	9,4
A-33	7,0	7,0	14,0	14,0	12,1	9,8	7,0	18,1	14,8	10,5
A-36S	7,5	7,5	15,0	15,0	12,9	10,5	7,5	19,4	15,9	11,2
A-36, A-36E	8,0	8,0	16,0	16,0	13,8	11,2	8,0	20,7	16,9	12,0
A-42, A-42S	10,0	10,0	20,0	20,0	17,3	14,1	10,0	25,9	21,2	15,0
A-48, A-48S	12,0	12,0	24,0	24,0	20,7	16,9	12,0	31,0	25,4	18,0
A-48L	15,0	15,0	30,0	30,0	25,9	21,1	15,0	38,8	31,8	22,5
B-24	0,95	0,95	1,9	1,9	1,6	1,3	0,95	2,4	2,0	1,4
B-30	1,5	1,5	3,0	3,0	2,5	2,1	1,5	3,8	3,1	2,2
B-36	2,3	2,3	4,6	4,6	3,9	3,2	2,3	5,9	4,8	3,4
B-42	3,4	3,4	6,8	6,8	5,8	4,7	3,4	8,8	7,2	5,1
B-48	4,3	4,3	8,6	8,6	7,4	6,0	4,3	11,1	9,1	6,4
B-64	9,0	9,0	18,0	18,0	15,5	12,6	9,0	23,3	19,0	13,5
BB-64, B-80, B-100	15	15	30,0	30,0	25,9	21,1	15,0	38,8	31,8	22,5
MB-64, MB-80, MB-100	20,0	20,0	40,0	40,0	34,6	28,2	20,0	51,8	42,4	30,0
C-10	0,5	0,5	1,0	1,0	0,86	0,7	0,5	1,2	1,0	0,75
C-16	1,6	1,6	3,2	3,2	2,7	2,2	1,6	4,1	3,3	2,4
C-24	4,0	4,0	8,0	8,0	6,9	5,6	4,0	10,3	8,4	6,0
C-36	8,0	8,0	16,0	16,0	13,8	11,2	8,0	20,7	16,9	12,0

* Manual issued September 2024. Product specifications are subject to change without notice to improve reliability, function or design.



www.martec.co.jp

info@martec.co.jp



MARTEC K.K.

Minatojima-nakamachi 5-1-1, Chuo-ku, Kobe 650-0046, JAPAN

Tel: +81-(0)78-302-0460 / Fax: +81-(0)78-302-1404