



Super Lock Hook

SLH-N
SLH-S

Operation Manual

This operation manual explains the basic operation and handling of the clamps. Please read this manual carefully before use and observe the precautions for safe operation.

SUPER TOOL CO., LTD.

 brand lock hooks are energy-saving lifting equipment which have been developed for the purpose of lifting operations during the laying and removal of steel floor plates or lifting operations using wire ropes, sling belts, etc.

Proper use

Operate lock hooks after carefully reading and understanding this operation manual for enhancing efficiency and safety of operation.

Prime efficiency and economy

Advanced functions, reasonableness and versatile applications of finely and carefully designed  brand lock hooks ensure prime efficiency and economy.

Special considerations on safety

We conduct a pulling test with a load three times of rated capacity and a manufacturing serial number is marked on each product, thus directing a special attention to safety.

Precautions for safety operation

Be sure to read this instruction manual carefully before use.

Mistaken use of super lock hook may cause a danger such as dropping of load.

Education of “crane safety regulations,” “operation manual for lifting clamp,” “your company’s operation standards,” etc. should be given before actual operation not only to business owners who have purchased clamps but also to their operators to ensure that actual operators have acquired enough knowledge, safety information, and precautions of the clamps.

Safety precautions are divided into two classifications in this manual; “Warning” and “Caution,”.



WARNING:

Indicates a potentially hazardous situation which, if not avoided, could result in death or serious injury.





CAUTION:

Indicates a potentially hazardous situation which, if not avoided, could result in medium damage or slight injury, or could result in property damage.

While only mentioned in  CAUTION, failure to comply with them still may lead to a serious disaster. As such, do not fail to pay attention both to WARNING and CAUTION which are of great importance.

Meanings of Signs

The signs of  and  indicate that precautions should be taken.

The contents of warning or caution are described at each sign.



The sign of  indicates prohibited actions.

The sign of  indicates that an action is enforced or instructed.







Two point lift for  righthand figure.

※ After reading this manual, make sure to keep it at a place of easy access by any users.





1. Handling in general

 WARNING	
<ul style="list-style-type: none"> ● Do not operate until the contents of the operation manual, and caution tag/plate are thoroughly read and understood. ● Do not operate without a legal qualification. ● Be sure to clear of the area of the operation for lifting or turning a load against possible drop off or fall over. ● Do not use for other than intended purpose. 	 Prohibited
<ul style="list-style-type: none"> ● Make sure to execute an inspection periodically and before each operation. 	 Instructed



2. Check before operation

 WARNING	
<ul style="list-style-type: none"> ● Do not use the lock hook unsuitable for the operation method. ● Do not use the lock hook of an abnormal condition; deformed, cracked, worn, malfunctioning, etc. ● If the load is under the following conditions, do not use the lock hook.(A material of fragile or extremely low-hardness.) 	 Prohibited
<ul style="list-style-type: none"> ● Check the type and rated capacity displayed on the main body. ● The load to be lifted shall be within an allowable range of rated capacity of the lock hook. ● The size of lifting hole of the load shall be within designated working range. 	 Instructed
 CAUTION	
<ul style="list-style-type: none"> ● Do not use the lock hook for the load under the following conditions. (Load to be lifted is more than 150°C, or in an atmosphere or solution of acid or alkaline chemicals less than minus 20°C.) 	 Prohibited
<ul style="list-style-type: none"> ● Sling to be used for lock hook shall be an appropriate one for lifting operation. 	 Instructed

3. Lifting operation

 WARNING	
<ul style="list-style-type: none"> ● Do not use lock hook for pulling out steel sheet piles. ● Do not use lock hook when strong wind may threaten to cause any danger. ● Do not use lock hook for a hydraulic shovel. 	 Prohibited
<ul style="list-style-type: none"> ● The lifting angle of lock hook and the dividing angle should be kept within the allowable angles according to types. ● When lifting and before leaving the ground, never fail to make sure that the close lock is applied. 	 Instructed
 CAUTION	
<ul style="list-style-type: none"> ● Do not drop lock hook or drag on the ground. 	 Prohibited

4. Operation of a crane

 WARNING	
<ul style="list-style-type: none"> ● Never lift a load exceeding the rated capacity. ● Do not operate a crane in such a way as to give an impact to the load or the lock hook. ● Do not allow a person to stand on the load or to carry him. ● Do not lift the load which is not free from any other objects. ● Do not release the lock of lock hook while lifting load. ● Avoid unintended contact by load to an adjacent member or to the lock hook, which has been removed from the load. 	 Prohibited
<ul style="list-style-type: none"> ● Stop the lifting operation by crane for a moment when the load is applied to the lifting ring for safety checking. (status of lock hook, angle of lifting, status of close lock). ● Stop the operation of the crane just before the load reaches the ground, and check the following matters: (Inclination or falling over of the load and security around the landing area of the load) 	 Instructed



CAUTION

- Do not operate the crane in such a way as to drag the load along the ground.
- Do not leave the crane (or winder, etc.) unattended from an operating position while keeping the load lifted with the lock hook.



Prohibited

- Raising and lowering operation by crane should be done slowly and carefully.



Instructed

5. Maintenance, storage and alteration



WARNING

- Never alter the lock hook and its accessories.
- Do not apply welding or heat to the lock hook or its accessories.
- Do not use any other parts than our company's genuine parts.
- Lock hooks which require the repair should be stored at a different place so that they are not used mistakenly.



Prohibited

- Persons with specialized knowledge designated by the business owner are to conduct maintenance and repairing work.
- When any abnormality with the lock hook is found, do not use it and immediately repair or dispose.



Instructed



CAUTION

- Conduct maintenance and repairing without any load attached.
- Conduct maintenance and repairing after posting a sign indicating that you're on the maintenance work.
- Never fail to lubricate oil on the rotating parts of the lock hook (around the pins), guide grooves, sliding parts, etc.
- Be sure to store clamps indoor.



Instructed

■ Maintenance and Inspection

1. Maintenance

Daily maintenance is important for efficient and safe operation even under the severe use condition and for such purposes, please comply with the followings.

- (1) Keep lock hook indoor and do not leave them outdoor.
- (2) Check the followings to maintain in a good condition.
 - (a) Operating condition.
 - (b) Any abrasion, damage, or clogging at teeth of cam and pad.
- (3) Separate conforming lock hook and other hazardous items identified during use or inspection and designate the defective sections.
- (4) Perform maintenance any soon.
- (5) Perform inspection and maintenance once a week by referring to “Inspection Standards”. Lubricate sliding sections periodically.

2. Periodic Inspection

Perform periodic inspection in accordance with the periodic inspection and maintenance standards. Functions and life of lock hook may differ in a great degree as they are used in varieties of fields under different conditions of use. Therefore, preparation and practice of effective handling/inspection standards manual by users themselves are recommended.

We ask you to establish complete maintenance and control for assurance of safety in reference to our Manufacturer’s Inspection Standards of our lock hook. Lock hook is designed for easy replacement of parts and therefore, do not fail to replace defective parts. Also, keeping spare parts at all times is recommended. For your preparation of the standards, pay special attention to the followings.

- (1) Operation and maintenance standards
 - (a) Preparation of use criteria (shape of load and operating methods).
 - (b) Thorough understanding and compliance of cautions on handling.
 - (c) Maintenance and storage.
 - (d) Rules of inspection and check at site.

- (2) Standards on periodic inspection
 - (A) Establishing dates of periodic inspection.
 - (B) Establishing inspection and maintenance methods.
 - (a) Inspecting period.
 - (b) Person in charge of the inspection.
 - (c) Inspection site.
 - (d) Tools and devices for inspection.
 - (e) Establishment of permissible limit of use.
 - (f) Explicit designation of maintenance and repair methods.

3. Manufacturer's inspection method

Our company's inspection procedures are as follow.

Check for

- (1) Movements.
- (2) Deformation of main body.
- (3) Deformation of shackle.
- (4) The status of bolts, pins, and springs.
- (5) Deep scratches in general.
- (6) Other checking items based on the Standards.

Lifting angle and rated load of wire rope

The maximum rated capacity of wire ropes also differs according to the lifting angle. Therefore, after paying attention to the lifting angle, always use wire ropes with the appropriate diameter.

Correlation table between the lifting angle and the applicable load for wire rope (for 2-point lifting)

■ JIS G 3525 6×24 A type

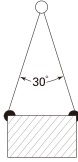
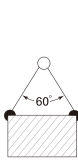
D wire rope diameter (mm)	W rated load (for 1 single rope) [Safety factor S=6] (ton)	  		
		(Change in % of the lifting capacity rate according to the lifting angle)		
		100%	96%	86%
Maximum allowable load (rated load) for 2 wire ropes (ton)				
6	0.30	0.60	0.57	0.51
8	0.53	1.07	1.03	0.92
9	0.67	1.35	1.30	1.16
10	0.83	1.67	1.61	1.44
12	1.20	2.41	2.32	2.08
14	1.64	3.28	3.15	2.83
16	2.14	4.28	4.12	3.69
18	2.72	5.44	5.23	4.69
20	3.35	6.70	6.44	5.77
22	4.06	8.12	7.81	7.00
24	4.82	9.65	9.28	8.32
26	5.66	11.3	10.8	9.76
28	6.58	13.1	12.6	11.3
30	7.55	15.1	14.5	13.0
32	8.58	17.1	16.5	14.8
36	10.8	21.7	20.8	18.7
40	13.4	26.8	25.8	23.1

Calculation formula of a wire rope diameter and rated load (for 1 single rope)

* Refer to the calculated values as rough indications.

① $D = \sqrt{W \times C}$

② $W = \frac{D^2}{C}$

D= wire rope dia. (mm)
W= rated load (ton)
C= 120 (constant)
(with Safety factor S = 6)

★ When looking for the required wire rope diameter to lift a 3 ton load

① $D = \sqrt{W \times C}$

$D = \sqrt{3 \times 120} = \sqrt{360} = 19 \rightarrow$

20mm

★ When looking for the maximum capacity (rated load) of a wire rope with 12mm diameter

② $W = \frac{D^2}{C}$

$W = \frac{12^2}{120} = \frac{144}{120} = 1.2 \rightarrow$

1.2ton



Super Lock Hook

SLH-N
SLH-S

Operation Manual and Inspection Standards



Super Lock Hook

SLH-N SLH-S

■ Uses

This lock hook is optimal for lifting operations during the laying and removal of steel floor plates in civil engineering and construction sites. It can also be used for a variety of lifting operations using wire ropes, sling belts, etc. or direct hook-up and lifting.

■ Features

1. The wide opening structure makes it easy to attach and remove lifting loads such as steel floor plates.
2. In caes of lifting steel floor plate, just inserting the end of the lock hook through the load by 30mm or more ensures an automatic mechanism of close lock on the opening, making the work safe and easy.
3. The main parts are mold forged product of special alloy steel processed with optimal heat treatment, and thus, strong and durable.

■ Specifications

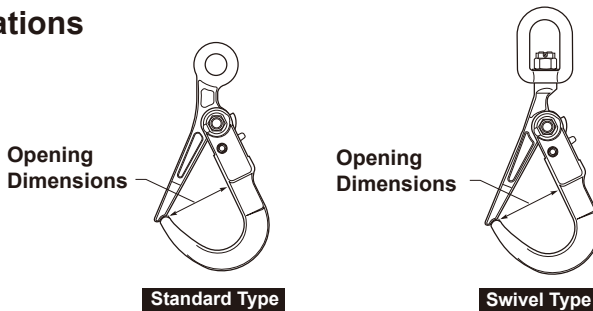

Type	Item No.	Rated Capacity (ton)	Opening Dimensions (mm)	Net Weight (kg)
Standard Type	SLH 1N	1	80	2.5
	SLH 2N	2	105	3.2
	SLH 3N	3	105	3.4
Swivel Type	SLH 2S	2	105	4.2
	SLH 3S	3	105	4.5

■ REPLACEMENT PARTS AND ASSEMBLIES

Part No.	Part Name	Item No.	Q'ty (pc)
※9	Swivel	SLHA	1
※	Castle Nut	SLHN	
※10	Castle Nut		1
※11	Washer		1
※12	Spring Pin (for Swivel)		1
1	Shackle	SLHH	1
	Support Bolt/Nut	SLHB	1
3	Support Bolt		1
4	Support Nut		1
5	Spring Pin		1
2	Lever	SLHL	
	Support Bolt	SLHC	
6	Support Bolt		1
7	U-Nut		1
8	Spring	SLHS	1

※1) When ordering, specify the rated capacity (ton) and with “N” or “S”.

(Example: Shackle for SLH2N is SLHH2N.)

(Example: Lever for SLH3S is SLHL3S.)

2) Parts marked with ※ are applicable only to the Swivel Type.

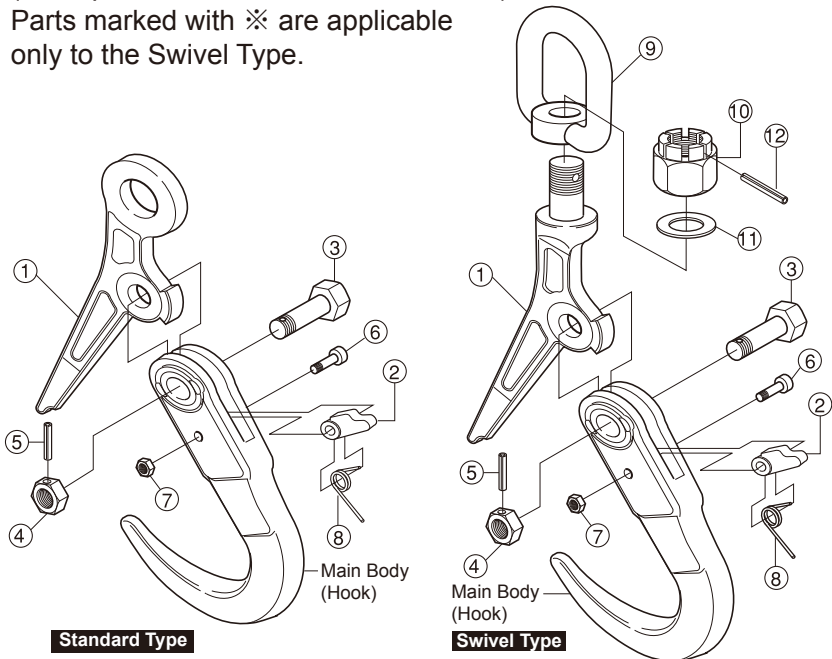

■ How to use (Common to Standard Type and Swivel Type)

1. OPERATION METHOD

- ① When you press down the lever, the shackle is in the free status. (Fig. 1)
- ② While keeping the lever pressed down, rotate the shackle until it comes to contact with the main body to make the mouth fully opened. At this time, take care not to have your finger pinched between the shackle and the main body. (Fig. 2)
- ③ When you take your finger off the lever, the shackle is fixed with the mouth kept opened. Hook up a load under this status.
- ④ When you add force to the shackle in the closing direction, it rotates and the close lock is applied.
- ⑤ In case of lifting a steel floor plate, when you insert the end of the lock hook through the hole of a steel floor plate by 30mm or more in the state of ③ and lift it up, then the shackle is automatically closed and close lock is applied.
- ⑥ When you remove the load from the lock hook, follow the operational procedure from ① to ③.

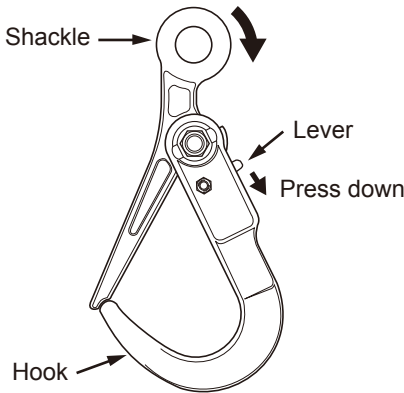

(Fig. 1)

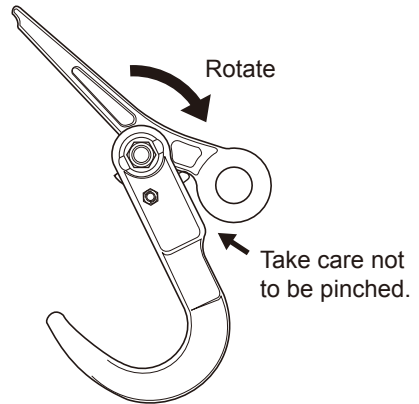

(Fig. 2)

2. OPERATION PATTERNS

① In case of using the lock hook for lifting floor steel plate

1) Check to see that the hole of a steel floor plate is appropriate in size and dimension for lifting. (Fig. 3)

- If the position of a hole for lifting is more than 60 mm away from the end of the steel floor plate, a swinging of the plate may cause the end of the plate to hit the shackle and damage some of the related parts, so that the use of such a plate is to be avoided. (Fig. 4)
- If the diameter of a hole for lifting is less than 60mm, the lock hook part cannot be inserted to the full, giving biased overload to the end of the hook, so that the use of such a plate is to be avoided. (Fig. 5)

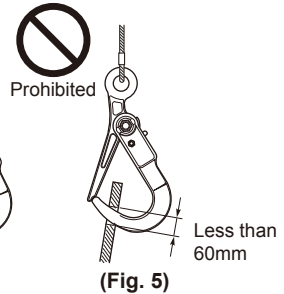
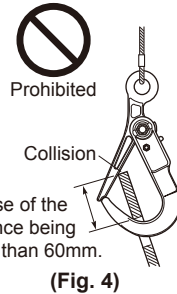
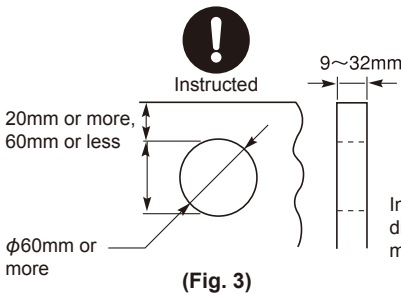

2) Insert the end of the lock hook through the hole of a floor steel plate by 30mm or more, while keeping the shackle in the open position. (Fig. 6)

- If you insert the end of the lock hook through the hole around the end of the steel floor plate, the end of the shackle may collide with the plate, disabling an application of close lock. So be sure to insert the end of the hook through the hole from above. (Fig. 7)

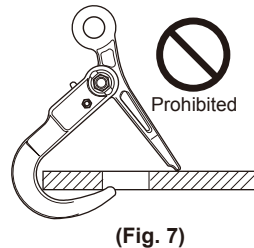
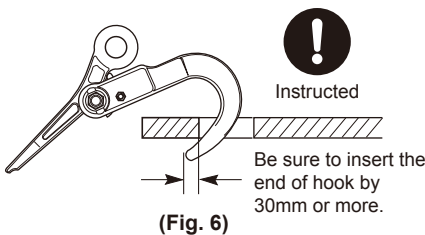

3) Vertically lift up the steel floor plate without giving impact on it. (Fig. 8)

- As you lift the plate upward, the steel floor plate rotates and close lock is automatically applied as shown in (Fig. 9). If the plate does not rotate smoothly or the close lock is not applied, stop lifting and lower the plate and then restart lifting up.

- When lifting, be sure to check that the close lock is applied before the steel floor plate leaves the ground.
- As there is a risk of the plate moving to an unexpected direction when lifting up, do not enter the specified danger zone.
- When lifting the installed steel floor plate, which may be buried in the ground or closely contacted with another, be careful not to overload.

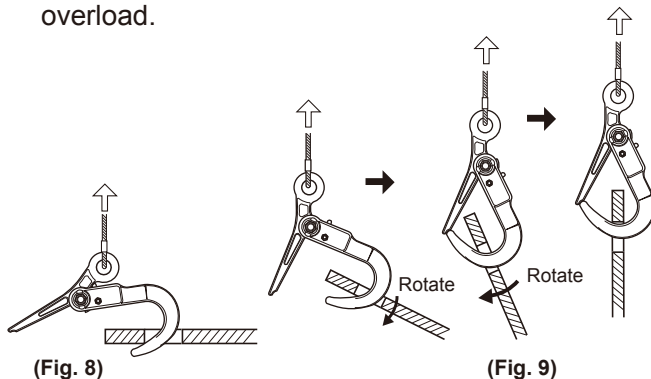

- 4) When you move the plate after lifting it up, slowly move it without swinging it or giving impact on it. And be sure to be careful of strong wind and confirm that there is no workers in the specified danger zone.
- 5) When landing the steel floor plate on the ground, lower it in the same direction as when lifting it up. (Fig. 10)
 - If the lock hook becomes slanted as the plate is slanted, re-lift it up and then lower it. If you lower the plate with the hook kept slanted, it may give biased overweight to the lock hook, damaging the hook. (Fig. 11)
 - Do not lower the plate in the opposite direction to that in which the plate is lifted up. If lowered in the opposite direction, the plate may collide with the end of the hook or the end of the shackle, and damaging them may cause. (Fig. 12)

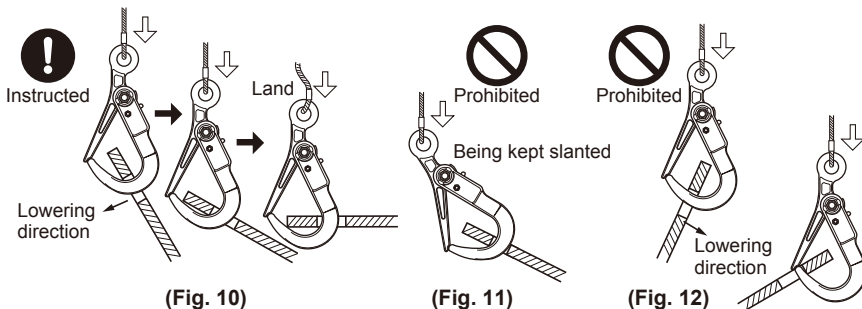

6) After having landed the floor steel plate, press down the lever to put the shackle in the open status. Press down the upper part of the hook in the arrow-head direction and rotate the hook to remove it from the plate. If it cannot be removed, forcibly remove it with a steel bar. (Fig. 13)

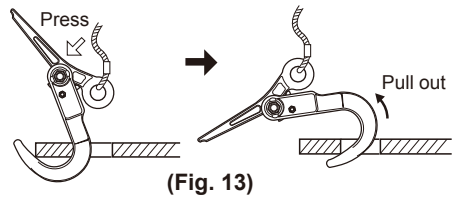

(Fig. 13)

7) When you stack steel floor plates in piles, don't overlap the holes, and keep a clearance of 35mm or more between plates. (Fig. 14)

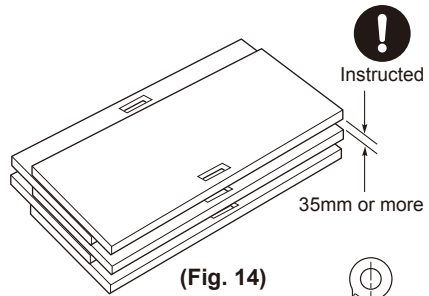

(Fig. 14)

② In case of using the lock hook with wire rope or sling belt

1) When using with the wire rope, apply it at the center of the lock hook.

- Be sure not to apply the wire rope in the part within 50mm from the end of the lock hook. The rope may slip in the direction of the end of the hook and be removed. (Fig. 15)

Do not use the part within 50mm.



Instructed

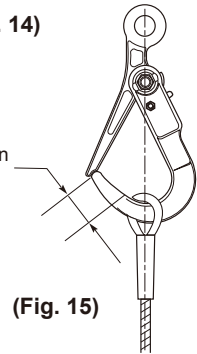

(Fig. 15)

2) In case of lifting the load at two points, the lifting angle should be within 30 degrees.

- In case of lifting the load at two points, it is safe to use master ring. (Fig. 17)

- Avoid applying biased overweight to the lock hook by working out the center of gravity of the load. If the load is lifted up with biased overweight on the lock hook, the ring of the rope may slip toward the end of the lock hook and be removed from the mouth. (Fig. 18)

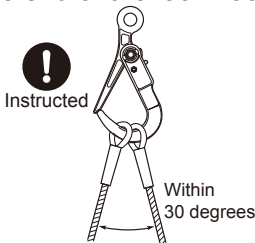

(Fig. 16)

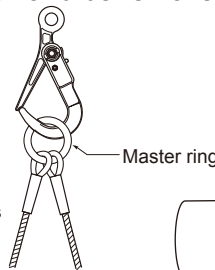

(Fig. 17)

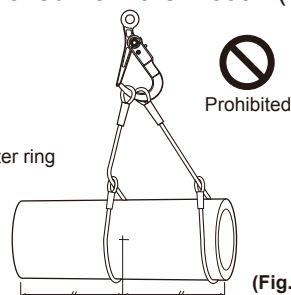

(Fig. 18)

3) Be sure not to directly apply load to the mouth of the lock hook and the shackle. Application of load to either of them may cause a forced opening of the shackle, removing the rope from the hook. (Fig. 19)

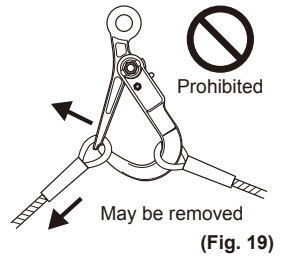

4) Never apply a folded rope on the lock hook. Be sure to have the eye part of the rope to be hooked. (Fig. 20)



③ **In case of using the lock hook for lifting with the eye piece**

Do not use an eye piece whose shape and dimensions are different from those specified as shown in the figure to the right. (Fig. 21)

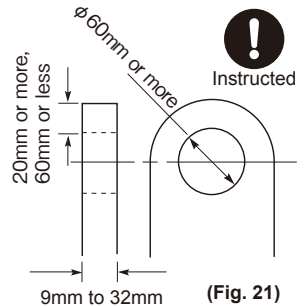

3. DISASSEMBLING AND ASSEMBLING

① **Disassembling (No.1-2 for Standard Type and No.1-3 for Swivel Type)**

- 1) Pull out the spring pin fixing the support nut for shackle with a pin punch and remove the support nut, and then remove support bolt and the shackle.
- 2) Remove the U-shaped nut fixing the bolt for the lever, and then remove the support bolt for the lever, the lever and the spring.
- 3) Remove the spring pin fixing the castle nut with a pin punch, and remove the castle nut and then the washer and the swivel.

② **Assembling**

Perform the reverse procedure of disassembling.

■ CAUTION:

- ◆ Use within the rated capacity.
- ◆ Do not lift the load unsuitable for the types and dimensions, as described in this operation manual.
- ◆ The load and lifting direction should be in a straight line. (Fig. 22)
- ◆ If the lock hook is tilted or the force is applied at an angle to the shackle when lifting, an unbalanced load will be applied and the lock hook may be damaged. (Fig. 23)

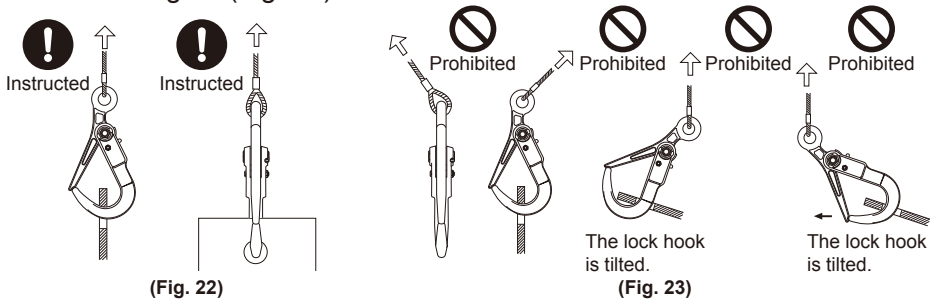

- ◆ Do not apply the lock hook to any other work such as pulling sheet piles not described in this operation manual.
- ◆ Do not lift two or more loads at one time.
- ◆ Be sure to confirm that the close lock is applied when lifting.
- ◆ Do not lift more than two loads at one time.
- ◆ Do not give any impact to the load or the lock hook.
- ◆ Before using the lock hook, be sure to check and inspect that no parts are abnormal. If the close lock is not be able to be applied, or any other abnormalities are found, stop using the lock hook.
- ◆ Do not alter. Heating, modifying, etc. will significantly reduce the quality (strength).
- ◆ The load may move to an unexpected direction when lifted off the ground and as such confirm the center of gravity and the clamping position for safety when lifting. Sufficient caution should be taken until the lock hook with the load becomes completely balanced.

- ◆ When changing directions of the load or any similar operations, all personnel must be clear of the area of operation. (Fig. 24)

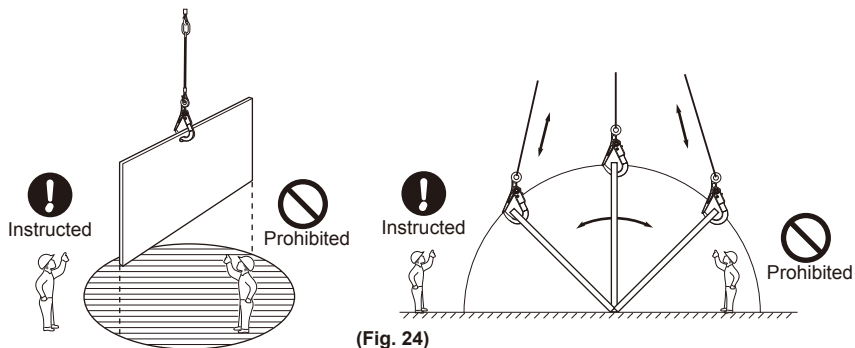

- ◆ Do not ride on the lifting load. Never use the lock hook for riding or carrying person.
- ◆ When lifting (especially when lifting down), special attention must be given to prevent the rope from loosening by its unintended contact with any other objects.
- ◆ Do not use clamp for heated load or in a corrosion liquid because safety factor and durability will be reduced in such conditions.
- ◆ Do not weld electrically a load while being lifted by clamp.
- ◆ Conduct daily maintenance and lubrication.

■ OTHER:



If repair parts or repairs are required, stop using this lock hook and contact your distributor.

■ Daily Inspection:

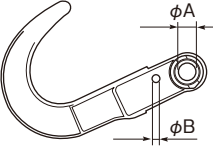
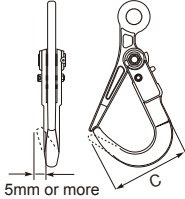

Conduct daily checks and maintenance to prevent the loss of safety and efficiency.

1. Check that there are no cracks at any parts of the lock hook or shackle.
2. Check if the bolts, nuts, and pins are installed in good condition.
3. Check if the movement and lubrication condition of each part are good.
4. Refer to other inspection standards.

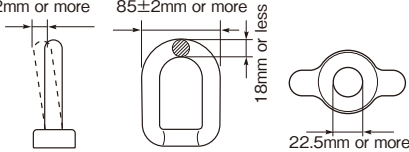
INSPECTION STANDARDS FOR SLH-A

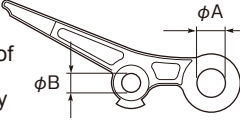
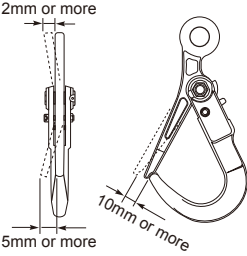
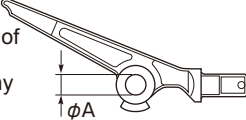
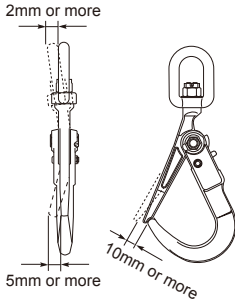
Item	Inspection method	Limit of use	Remedy												
<p>Main Body</p>	<p>Visually check or use color dyes to find cracks.</p> <p>Measure to find wear or deformation of holes of bolts.</p>	<p>When found visually.</p>  <p>When the diameter of any one part of circumference of any hole exceeds the respective size below.</p> <table border="1" data-bbox="516 424 852 496"> <thead> <tr> <th>Rated Capacity (ton)</th> <th>1</th> <th>2</th> <th>3</th> </tr> </thead> <tbody> <tr> <td>A (mm)</td> <td>16.5</td> <td>20.5</td> <td>20.5</td> </tr> <tr> <td>B (mm)</td> <td>8.5</td> <td>8.5</td> <td>8.5</td> </tr> </tbody> </table>	Rated Capacity (ton)	1	2	3	A (mm)	16.5	20.5	20.5	B (mm)	8.5	8.5	8.5	<p>Discard</p>
	Rated Capacity (ton)	1	2	3											
	A (mm)	16.5	20.5	20.5											
B (mm)	8.5	8.5	8.5												
<p>Measure to find deformation of any parts.</p>	<p>When the degree exceeds the respective size below.</p>  <table border="1" data-bbox="521 783 846 839"> <thead> <tr> <th>Rated Capacity (ton)</th> <th>1</th> <th>2</th> <th>3</th> </tr> </thead> <tbody> <tr> <td>C (mm)</td> <td>128</td> <td>153</td> <td>156</td> </tr> </tbody> </table>	Rated Capacity (ton)	1	2	3	C (mm)	128	153	156						
Rated Capacity (ton)	1	2	3												
C (mm)	128	153	156												
<p>Visually check to find wear or deformation of lifting parts.</p>	 <p>When sharp wear or deformation occurs.</p>														
<p>Swivel (Swivel Type)</p>	<p>Visually check or use color dyes to find cracks.</p> <p>Measure to find wear or deformation of any parts.</p>	<p>When found visually.</p> <p>When the degree exceeds the respective size below.</p> 	<p>Replace</p>												
<p>Castle Nut (Swivel Type)</p>	<p>Visually check if the nut and spring pin are installed in good condition.</p>	<p>When found damage, looseness or disconnection.</p>	<p>Replace</p>												

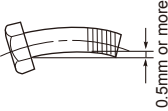
Item	Inspection method	Limit of use	Remedy												
Washer (Swivel Type)	Measure to find wear or deformation.	When the thickness of the wear part is less than 2.7 mm.	Replace												
Shackle (Standard Type)	<p>Visually check or use color dyes to find cracks.</p> <p>Measure to find wear or deformation of holes.</p> <p>Measure to find deformation.</p>	<p>When found visually.</p>  <p>When the diameter of any one part of circumference of any hole exceeds the respective size below.</p> <table border="1" data-bbox="557 443 890 515"> <thead> <tr> <th>Rated Capacity (ton)</th> <th>1</th> <th>2</th> <th>3</th> </tr> </thead> <tbody> <tr> <td>A (mm)</td> <td>25.0</td> <td>33.0</td> <td>33.0</td> </tr> <tr> <td>B (mm)</td> <td>16.5</td> <td>20.5</td> <td>20.5</td> </tr> </tbody> </table> <p>When the degree exceeds the respective size as shown on the right.</p> 	Rated Capacity (ton)	1	2	3	A (mm)	25.0	33.0	33.0	B (mm)	16.5	20.5	20.5	Replace
Rated Capacity (ton)	1	2	3												
A (mm)	25.0	33.0	33.0												
B (mm)	16.5	20.5	20.5												
Shackle (Swivel Type)	<p>Visually check or use color dyes to find cracks.</p> <p>Measure to find wear or deformation of holes.</p> <p>Measure to find deformation.</p>	<p>When found visually.</p>  <p>When the diameter of any one part of circumference of any hole exceeds the respective size below.</p> <table border="1" data-bbox="588 1005 856 1053"> <thead> <tr> <th>Rated Capacity (ton)</th> <th>2</th> <th>3</th> </tr> </thead> <tbody> <tr> <td>A (mm)</td> <td>20.5</td> <td>20.5</td> </tr> </tbody> </table> <p>When the degree exceeds the respective size as shown on the right.</p> 	Rated Capacity (ton)	2	3	A (mm)	20.5	20.5	Replace						
Rated Capacity (ton)	2	3													
A (mm)	20.5	20.5													

Item	Inspection method	Limit of use	Remedy												
Support Bolt and Nut	<p>Measure to find wear of shaft part of bolts.</p> <p>Visually check or use color dyes to find cracks.</p> <p>Visually check or measure for deformation.</p> <p>Visually check if the nuts and spring pins are installed in good condition.</p>	<p>When the diameter of any one part of circumference of any shaft part is less than the respective size below.</p> <table border="1" data-bbox="497 236 876 312"> <thead> <tr> <th>Rated Capacity (ton)</th> <th>1</th> <th>2</th> <th>3</th> </tr> </thead> <tbody> <tr> <td>Shackle Support Bolt (mm)</td> <td>15.5</td> <td>19.5</td> <td>19.5</td> </tr> <tr> <td>Lever Support Bolt (mm)</td> <td>7.5</td> <td>7.5</td> <td>7.5</td> </tr> </tbody> </table> <p>When found visually.</p> <p>When deformation exceeds 0.5mm.</p>  <p>When found damage, looseness or disconnection.</p>	Rated Capacity (ton)	1	2	3	Shackle Support Bolt (mm)	15.5	19.5	19.5	Lever Support Bolt (mm)	7.5	7.5	7.5	Replace
Rated Capacity (ton)	1	2	3												
Shackle Support Bolt (mm)	15.5	19.5	19.5												
Lever Support Bolt (mm)	7.5	7.5	7.5												
Lever	<p>Measure to find wear or deformation of holes.</p> <p>Check if the close lock is able to be applied.</p>	<p>When the diameter of any hole exceeds 8.5mm.</p>  <p>When the close lock is not applied even if there are no abnormalities in the resilience of spring.</p>	Replace												
Spring	<p>Check if there is appropriate resilience when pushing lever.</p> <p>Check if the close lock is able to be applied.</p>	<p>When there is no normal resilience due to deformation or other reasons and the lever does not move smoothly.</p> <p>When the close lock is not applied securely.</p>	Replace												